

This machine is suitable for DRY use only.

Make sure that the filtration system fitted to the machine is suitable for the material being collected.

Numatic

numatic.com



HZC 390S-2 HZC 390L-2 1000W (Kit AA16)

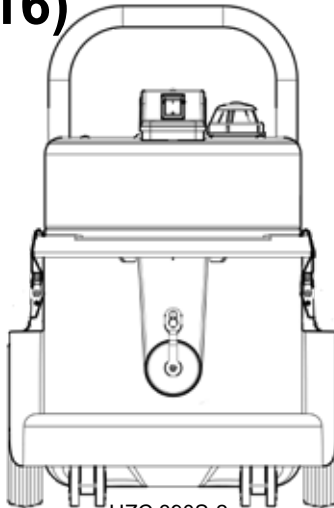

HZC 390S-2

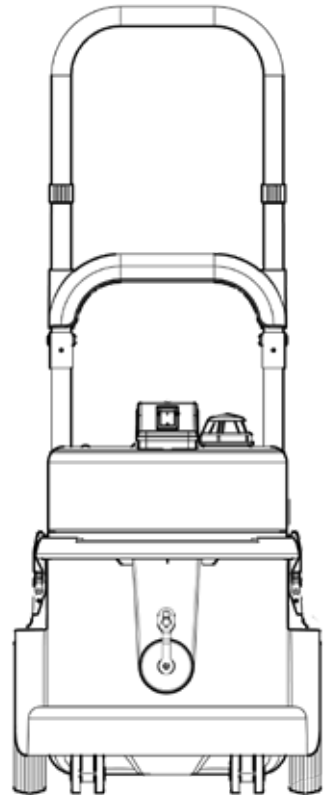

HZC 390L-2



Original Instructions

CAUTION, Read the Instructions before using the machine.

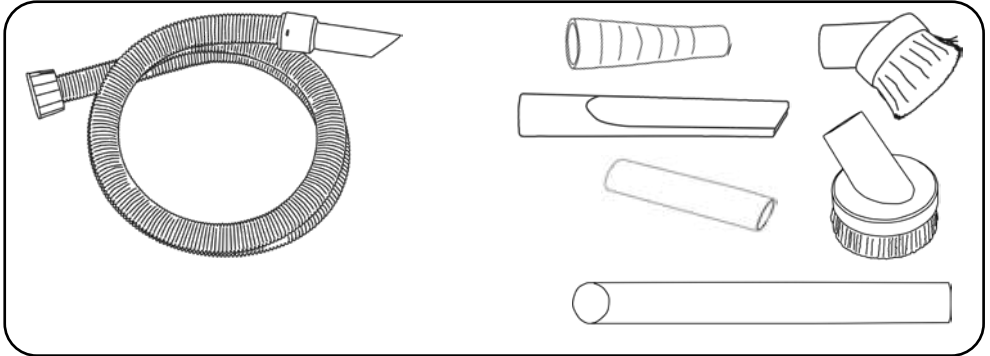

601101 2.4 NuFlex Threaded Hose

602161 152mm Rubber Dusting Brush with soft bristles

601142 240mm Crevice tool

602159 38 / 32mm Adaptor

601144 65mm Soft dusting brush

601141 Double taper hose / tool adaptor

601917 280mm Stainless steel gulper / scraper tool

Handle Assembly

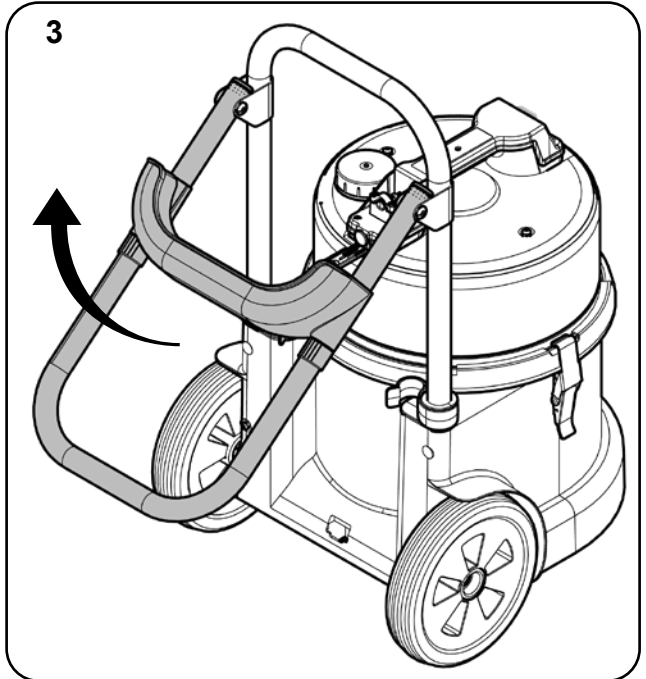
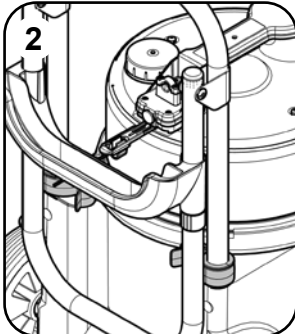
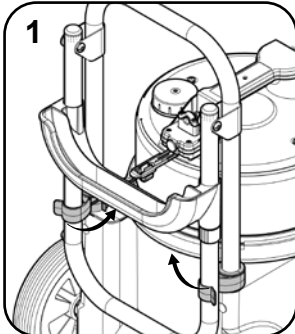

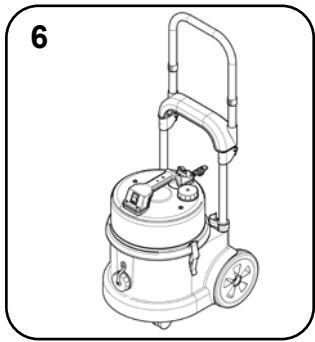
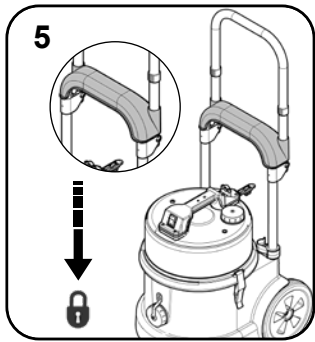
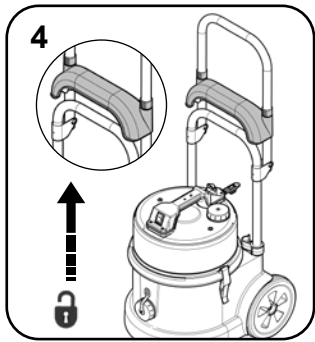

Air Diffuser

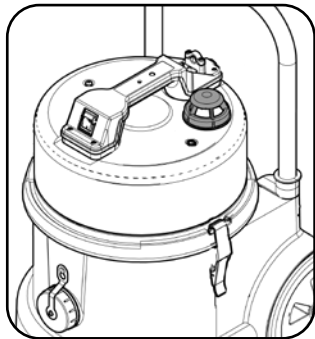
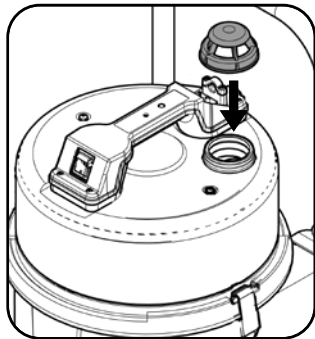
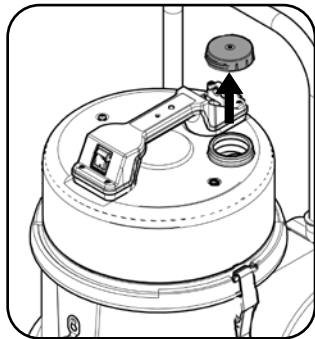

Hose

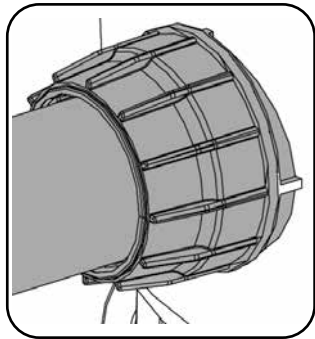
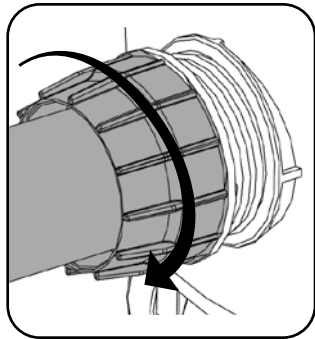
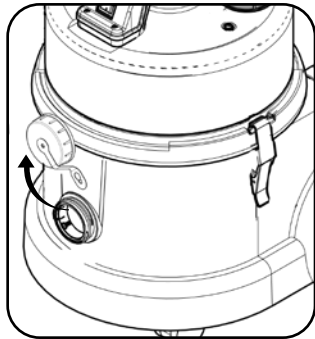

Machine Function

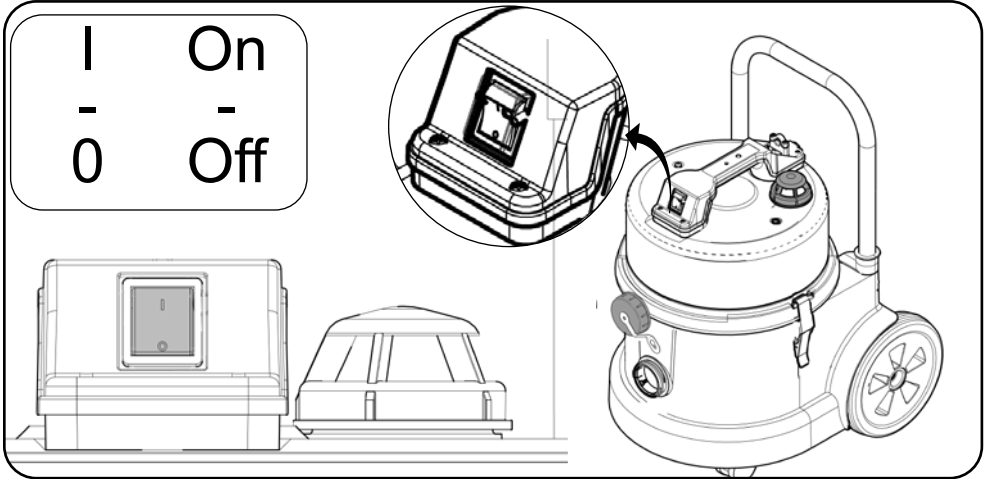

Moving your Machine

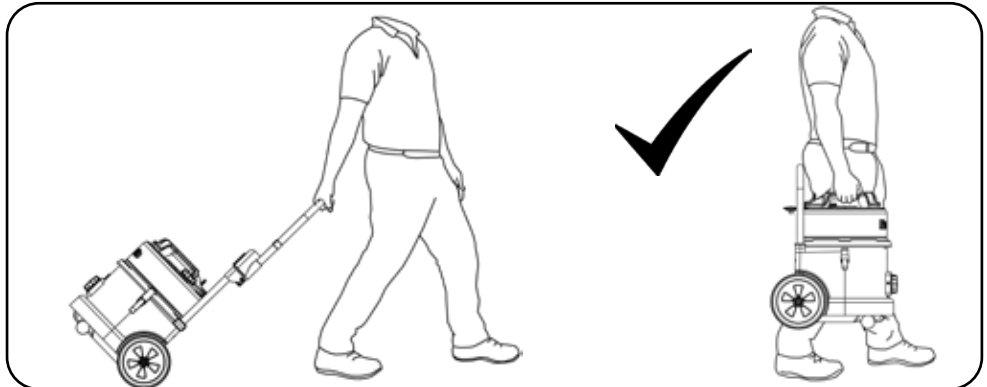
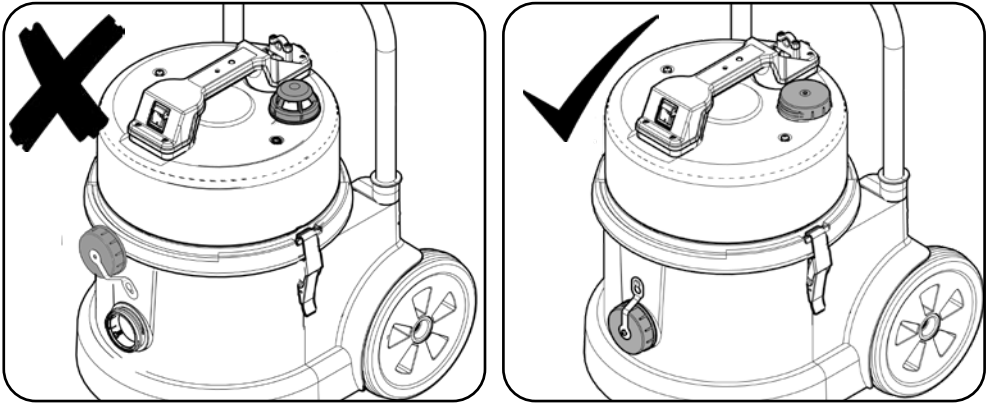

Replacing the Cartridge Filter

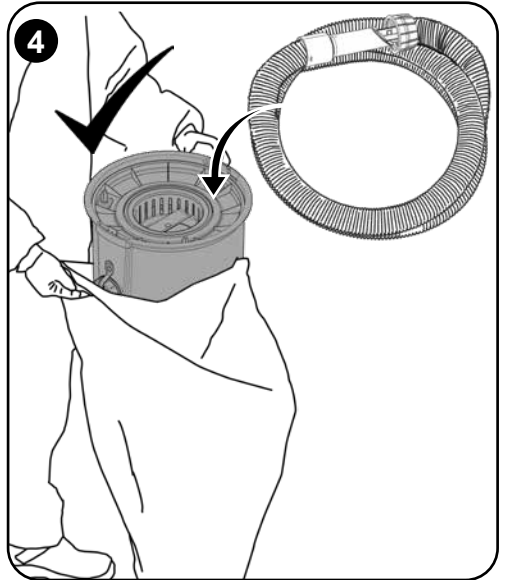
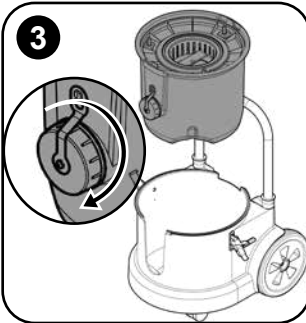
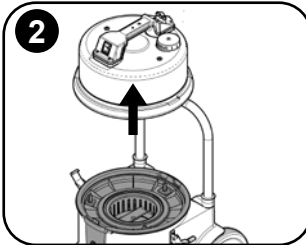
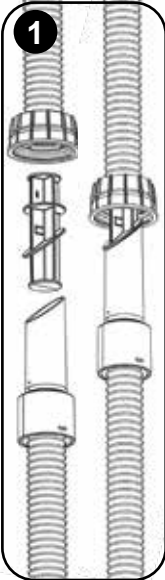
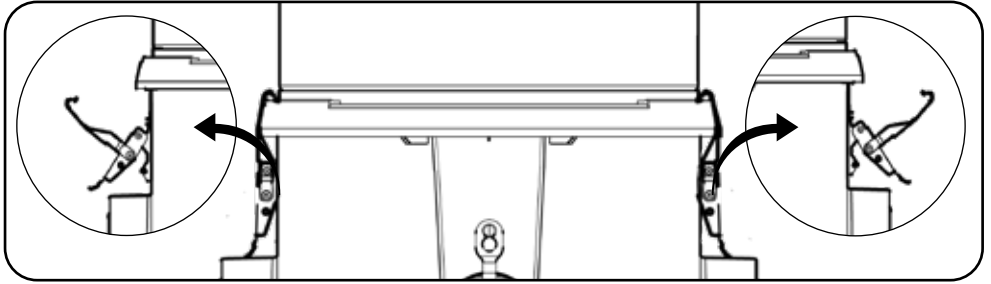

1. Seal contaminated hose using bung supplied.
- 2/3. Remove the sealed H Class Filter Unit from the drum.
4. Place the Filter Unit and Hose Assembly inside an impervious plastic bag and seal the bag.
Dispose of the plastic bag, depending on contamination, in an appropriate manner.

Note* Filter unit is sealed do not attempt to open and reuse.

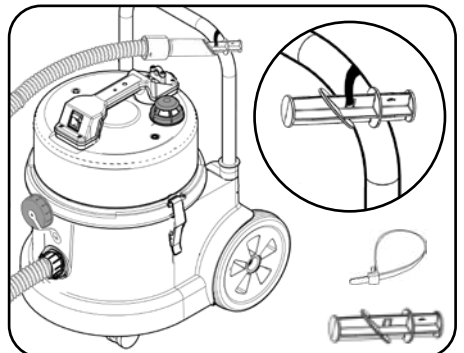
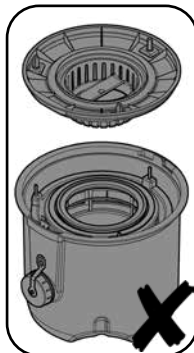
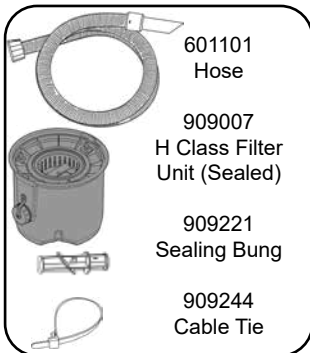

Low Flow Warning Light

Lo - Flo Indicator.

Slow Repeated Flash.

The vacuum cleaner is fitted with a warning lamp that will illuminate and flash when the air speed in the suction hose falls below $<20\text{m/s}$.

This indicates that the filter cartridge requires changing.

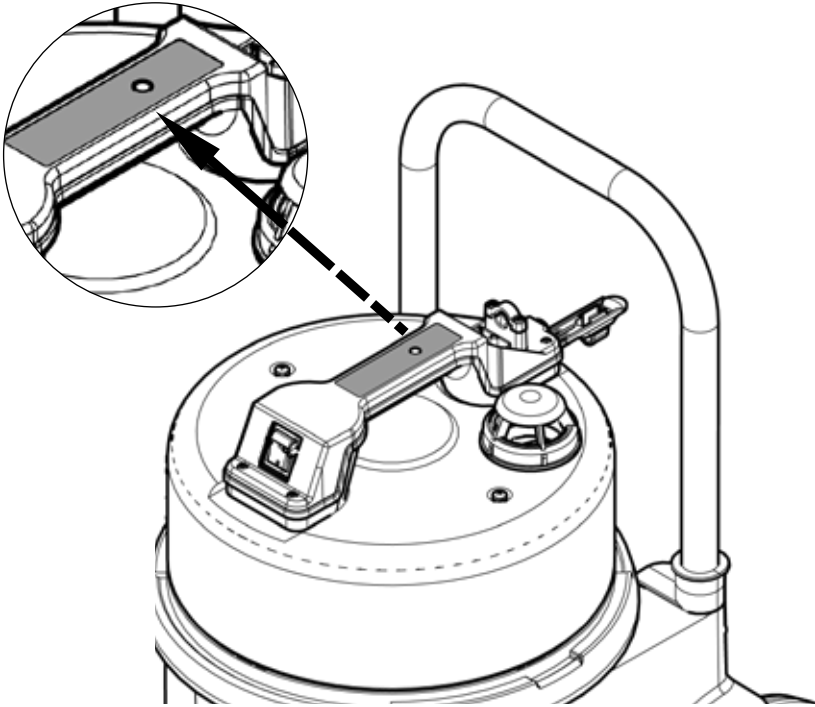

Cause	Solution
Suction hose blocked or kinked.	Remove blockage or kink.
Filter clogged or blocked.	Replace filter cartridge.

Changing / Replacing Cable

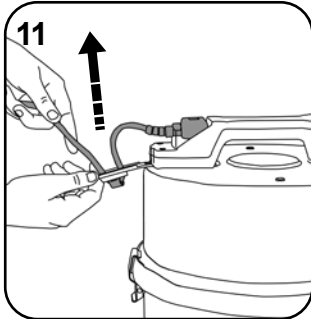
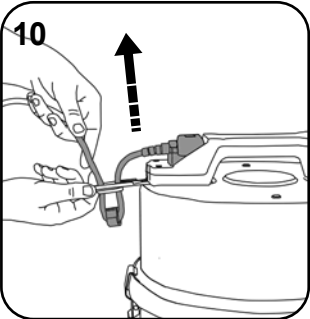
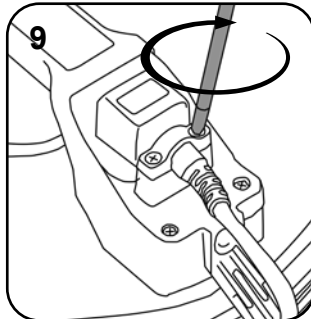
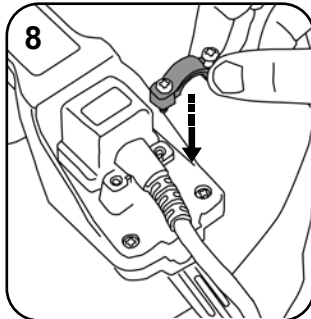
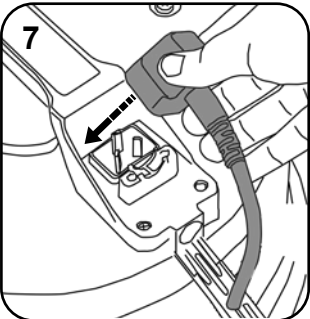
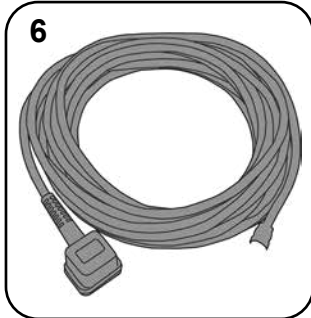
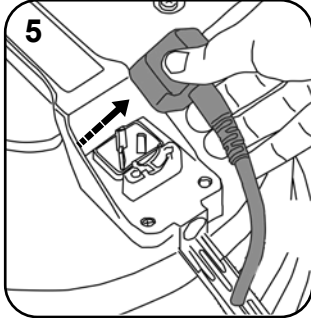
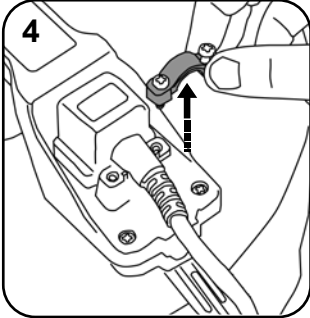
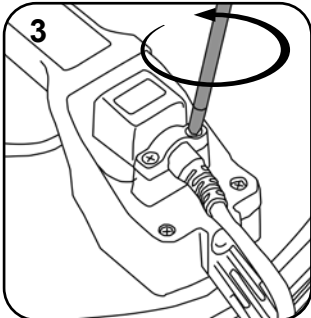
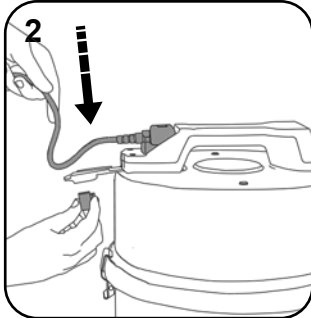
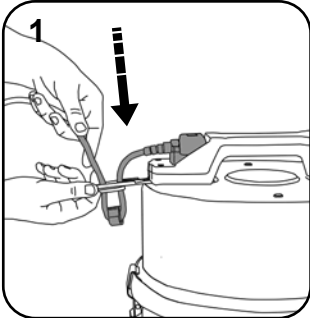

(EN) About your machine

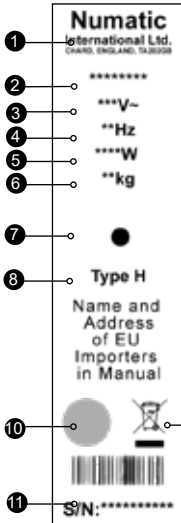

Rating Label

1	Company Name & Address
2	Model
3	Voltage / Alternating Current
4	Frequency
5	Rated Input Power
6	Weight
7	Low Flow Indicator *(If applicable)
8	Hazardous Rating
9	WEEE Logo
10	Approval Mark
11	Machine yr/wk Serial Number

Daily

Keep the machine clean, including hoses and tubes. Ensure the bag and filter are fitted. Regularly examine the power cord. Check dust bag frequently. Check filters are clean.

Weekly - as daily and:-

Check for any worn or damaged parts and replace immediately.

Maintenance

WEEE Legislation (Waste, Electrical and Electronic Equipment)

Vacuum cleaner, accessories and packaging should be sorted for environmentally - friendly recycling.

(Only for UK/EU Countries)

Do not dispose of vacuum cleaner into household waste! According to the European Directive 2012/19/EU on waste electrical and electronic equipment and its incorporation into national law.

Vacuum cleaners that are no longer suitable for use must be separately collected and sent for recovery in an environmentally - friendly manner.



PPE (personal protective equipment). That may be required for certain operations.

Ear Protection	Safety Footwear	Head Protection	Safety Gloves	
Eye Protection	Protective Clothing	Dust / Allergens Protection	Hi Viz Jacket	

NOTE: A risk assessment should be conducted to determine which PPE should be worn.

Failure to rectify the problem or in the event of a breakdown contact your Numatic dealer or the Numatic Technical helpline +44 (0)1460 269268

Safety Critical Components

Mains leads:

H05VV-F 10 m x 3 Core x 1.0 mm²
(110V) H05VV-F 10 m x 3 Core x 1.5 mm²

WARNING

Read the instruction manual before using the machine.
Operators shall be adequately instructed on the use of these machines.

As with all electrical equipment, care and attention must be exercised at all times during use, in addition to ensuring that routine and preventative maintenance is carried out periodically to ensure safe operation.

Failure to carry out maintenance as necessary, including the replacement of parts to the correct standard could render this equipment unsafe and the manufacturer can accept no responsibility in this respect.

This machine is for DRY USE only and must not be stored outside or used in wet conditions.
The machine shall be disconnected from the mains by removing the plug from the supply socket during cleaning or maintenance and when replacing parts or converting the machine to another function.

This machine is not to be used by children or persons with reduced physical, sensory or mental capabilities, or lack of experience or knowledge.

Children should be supervised to ensure they do not play with the machine
This machine is not a toy.

Ensure that the filtration system fitted to the machine is suitable for the material being collected.

CAUTION

This machine is for use indoors only.
This machine should be stored indoors only.

NOTES

This product complies with the requirements of clause 20 of IEC/EN 60335-2-69 Stability and Mechanical Hazards.

This machine is intended for commercial use, for example in hotels, schools, hospitals, factories, shops, rental businesses and offices for other than normal housekeeping purposes.

DO

- Keep your machine clean.
- Keep hoses and tubes clear.
- Replace any worn or damaged parts immediately.
- Regularly examine the power cord. If damage is found such as cracking or ageing the power cord must be replaced by a qualified person using the correct Numatic original part.
- Change 908082 H Class Filter Unit with the correct Numatic approved replacement part.
- Only use the brushes provided with the machine. The use of other brushes may impair safety.
- Only replace the power cord with the correct Numatic approved replacement part.

DO NOT

- Unreel the cable with one pull or pull on the cable to unplug the machine from the power supply.
- Use to suck up hot ashes or lighted cigarette ends.
- Use steam cleaners or pressure washers to clean the machine or use in the rain.
- Immerse in water for cleaning.
- Attempt machine maintenance or cleaning unless the power supply plug has been removed from the supply outlet.
- Under any circumstances place foreign objects including (but not limited to) air fresheners, air freshener capsules or scented beads of any type into the top filter of the machine. Doing so can be dangerous and risk damage to the machine and may invalidate the machine warranty.

IMPORTANT USER INFORMATION

Before use operators shall be provided with information, instruction and training for the use of the machine and the substances for which it is to be used, including the safe method of disposing of material collected.

The cartridge filter has to be replaced when necessary.

This vacuum cleaner has a lamp that illuminates when air velocity drops below a preset level, which indicates that the cartridge filter must be changed.

This machine is not suitable for connection with dust generating machines.

The cartridge filter must be undamaged and in correct position before this machine can be used safely.

WARNING:

1. This machine must only be operated by suitably trained and authorised personnel.
2. This machine or its accessories must not be modified.
3. The machine must not be stored or used in a wet environment.
4. Do not allow the cartridge filter to become so full as to reduce the effective pick-up of the vacuum. (Lamp will illuminate at preset air velocity levels < 20 m/s).
5. This machine must only be repaired by suitably trained and authorised personnel.
6. Only use genuine Numatic International Ltd spare parts, for repairs.
7. This machine must not be installed as a fixed extraction system or run unattended.
8. Do not re-use the essential filter element after removal out of the machine.

Operators should observe any safety regulations appropriate to materials being handled.

This machine is for dry use only.

PREPARATION FOR USE

Unpack and identify each item of equipment from the delivery note.

Check that the details given match the information on the "rating plate" mounted on the head assembly.

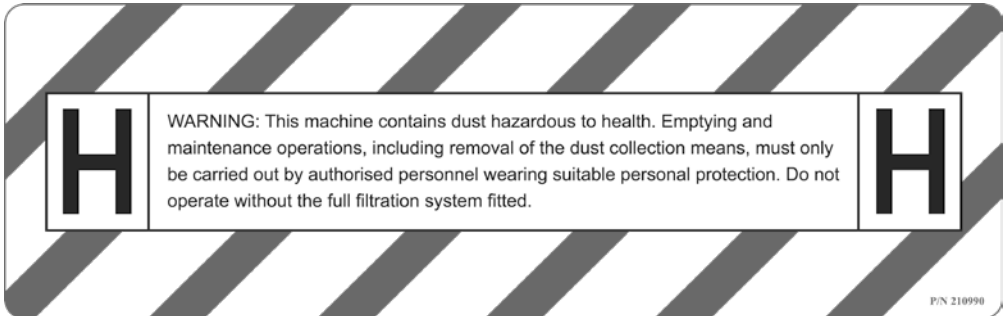

Installation / Removal / Disposal of the cartridge filter.

The cartridge filter holding the dust and debris must be removed and renewed by authorised personnel only, wearing appropriate personnel protective equipment, in a specified de-contamination area.

Never operate without the full filtration system in place.

Process of disposal:

Disconnect the hose, fit the Dust Cap on the Hose Flange, un-clip the two Toggle Clamps.

Remove the cartridge filter from the Drum. Place the cartridge filter inside an impervious plastic bag and seal the bag.

Dispose of the plastic bag, depending on contamination, in an appropriate manner.

MAINTENANCE

All machine parts should be regarded as contaminated when removed from the hazardous area and appropriate action taken to prevent dust dispersal.

Disconnect from the power supply during cleaning, maintenance or when replacing parts.

Ensure the plug is removed from the socket outlet.

Maintenance must be carried out in a suitable non hazardous area with facilities for cleaning the area after servicing, and with suitable ventilation.

Maintenance and cleaning work must always be carried out by competent authorised personnel equipped with suitable personal protection.

The cartridge filter must be taken out and checked for degree of contamination, and damage to seals.

If the cartridge filter is found to be damaged or badly contaminated, you must replace.

Items that can not be satisfactorily cleaned (e.g. filter) need to be disposed of in an impervious plastic bag and disposed of in accordance with current regulations.

Replace the items that cannot be satisfactorily cleaned using approved manufacturer parts.

Regularly examine the supply cord for damage, such as cracking or ageing. If damage is found, replace the cord before further use.

All parts of this vacuum are safety critical only replace with the genuine Numatic spare parts.

For user servicing, the machine must be dismantled, cleaned and serviced, as far as is reasonably practicable, without causing risk to maintenance staff and others.

Suitable precautions include decontamination before dismantling, provision for local filtered exhaust ventilation where the machine is dismantled, cleaning of the maintenance area and suitable personal protection.

In class H machines the outside of the machine should be decontaminated by vacuum cleaning methods and wiped clean or treated with a sealant before being taken out of the hazardous area and appropriate action taken to prevent dust dispersal. (HSE Risk Assessment needed).

A qualified person must perform at least once a year - or more frequently if national requirements dictate - the filtering efficiency of the filter cartridge must be checked, or the filter cartridge must be replaced, a filter inspection to look for signs of damage, checking the tightness of the machine and correct operation of the control mechanism.

Also the filtration efficiency should be tested at least annually, or more frequently as specified in national requirements.

The test methods that can be used to verify the machine's filter efficiency are specified in EN 60335-2-69 Annex AA (AA22.201.2). If the test fails it should be repeated with a new cartridge filter.

Replacement Parts

909007	H Class Sealed Filter Kit
--------	---------------------------

Data

	Drum Size	Cleaning Range	Weight (Ready to work)	Sound Pressure (LpA) Uncertainty (KpA)		Protection Class
HZC 390S-2 HZC 390L-2	13 L 13 L	26.4 m	12.2 kg 13.0 kg	74.48 dB (A) 0.5 dB		Class I
Dimensions L x W x H		Low flow operation	Voltage Frequency	Power Rating	Max. Under pressure	Max. Flow rate
(S) 450 x 400 x 600mm (L) 450 x 400 x 1010mm		< 20 L/sec	110V 220-240V 50-60 Hz	1000W	230 Mbar 230 (hPa)	31.8 L/sec 114.5 m ³ /h

Schematic Diagram

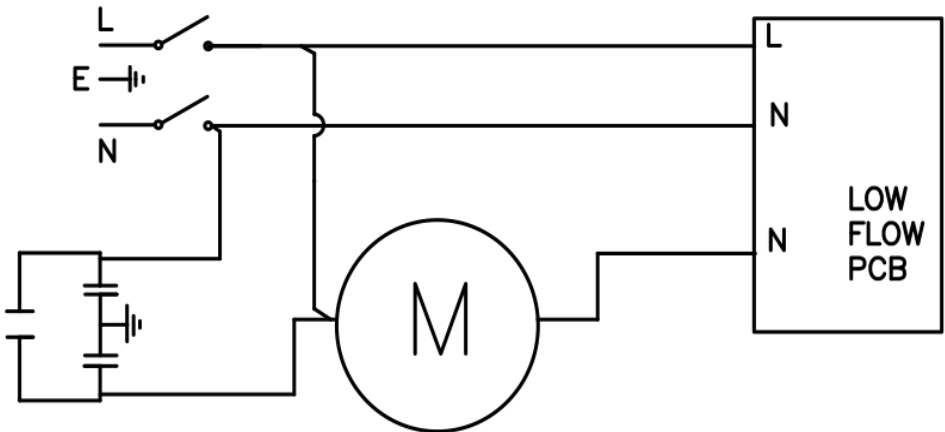

Notes

A series of 30 horizontal dotted lines for writing notes.

Numatic International Warranty

Numatic International Limited warrant to the original purchaser that its products are free of defects in both material or workmanship for the period shown below:-

Homecare and Cleancare Vacuum cleaners.....	2 Years
Rotary Floor Machines.....	2 Years
Twintec Auto Scrubber Dryer.....	1 Year
Vario Ride-On Scrubber Dryer.....	1 Year / 1500 hours
Mopping, Compacts, Combi and Servocare Products.....	1 Year
Individual Accessories and Spare Parts.....	6 Months

Note: This warranty expressly excludes consumable parts such as carbon brushes, floor brushes, mops, batteries etc, that are considered replaceable from time to time during the normal working life of the machine.

Using non Numatic dustbags can be detrimental to both machine performance and life and may invalidate the Warranty.

A. The warranty period commences from the date the goods are purchased.

B. All warranty claims must be processed through the Dealer from whom the equipment was purchased. The Dealer will co-operate with the purchaser throughout the warranty claims procedure and will arrange any necessary repairs using genuine Numatic parts.

C. If the original Dealer is no longer able to fulfil his obligations please contact Numatic International Limited with full details of the claim and proof of purchase so that this may be processed without delay.

D. Any warranty claim can only relate to the specific part that is proven to be at fault and for which a replacement will be supplied but cannot be extended to constitute a claim against the complete machine.

E. Numatic International will supply the Dealer with any warranty parts required, subject to the claim being validated, after return of the faulty items in accordance with Numatic International Limited's General Conditions of Sale.

F. Claims will not be accepted if they are the result of fair wear and tear, misuse or abuse of any kind.

G. No replacement will be given unless the appropriate evidence of the validity of the claim has been provided to the satisfaction of Numatic International Limited.

H. Numatic International Limited reserve the right to charge for any unnecessary work carried out as a result of an invalid claim.

I. No variation to this warranty may be made or implied by any member of Numatic International Limited or its Dealers unless such variation is in writing and authorised by the Company

Numatic

Numatic International Limited. Chard, Somerset, TA20 2GB
Telephone: 01460 68600 Fax: 01460 68458

© Numatic International Limited

Numatic

numatic.com

Affix Label Here

Numatic International Limited (Head Office)
Chard, Somerset TA20 2GB, UNITED KINGDOM
Tel: 01460 68600 numatic.com

Numatic International GmbH
Fränkische Straße 15-19, 30455 Hannover, DEUTSCHLAND
Tel: +49 (0) 511 984 2160 numatic.de

Numatic International Denmark
Fränkische Straße 15-19, 30455 Hannover, DEUTSCHLAND
Tel: +45 (0) 316 40808 numatic-online.dk

Numatic International S.A.S
13/17 rue du Valengelier, EAE la Tuilerie, 77500 Chelles, FRANCE
Tel: +33 (0) 164 726 161 numatic.fr

Numatic International BV
Vennootsweg 15, 2404 CG, Alphen aan den Rijn, NEDERLAND
Tel: +31 (0) 172 467 999 numatic.nl

Numatic International Schweiz AG.
Sihlbruggstrasse 3A, 6340 Baar, SCHWEIZ
Tel: +41 (0) 41 768 0760 numatic.ch

Numatic International (PTY) Ltd.
Cnr. 16th & Pharmaceutical Road, Randjes Park, Midrand 1685, SOUTH AFRICA
Tel: +27 (0) 861 686 284 numatic.co.za

Numatic International ULDA
Rua Francisco da Silva Duarte, nº79,
4475-269 Santa Maria de Avioso, Castelo da Maia, PORTUGAL
Tel: +351 220 047 700 numatic.pt

NUMATIC INTERNATIONAL SPAIN, S.L.U.
Av. Baix Llobregat, 5-7, Oficina bajos 1 (Parc Negocis Mas Blau II),
08820 El Prat de Llobregat (Barcelona) SPAIN
Tel: +34 93 647 22 22 numatic.es

Numatic International Italy S.R.L
Via Luigi Galvani, 2, Z.I. Talponedo, 33080 Porcia (PN), ITALY
Tel: +39 (0) 434 046 211 numatic.it