

ATTIX 30-40-50 PC/XC

ATTIX 50-21 PC EC

Instructions for use

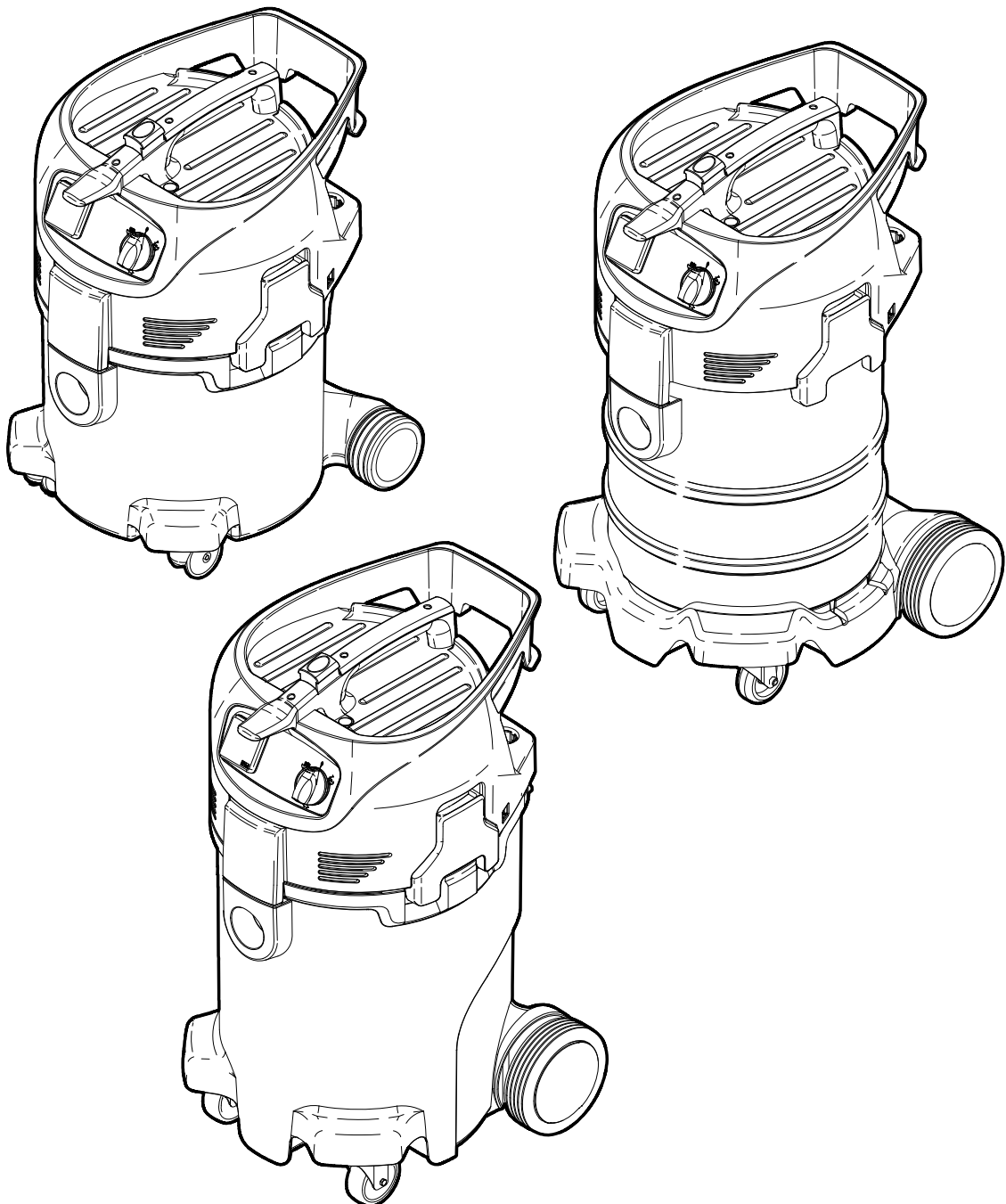

ATTIX 30

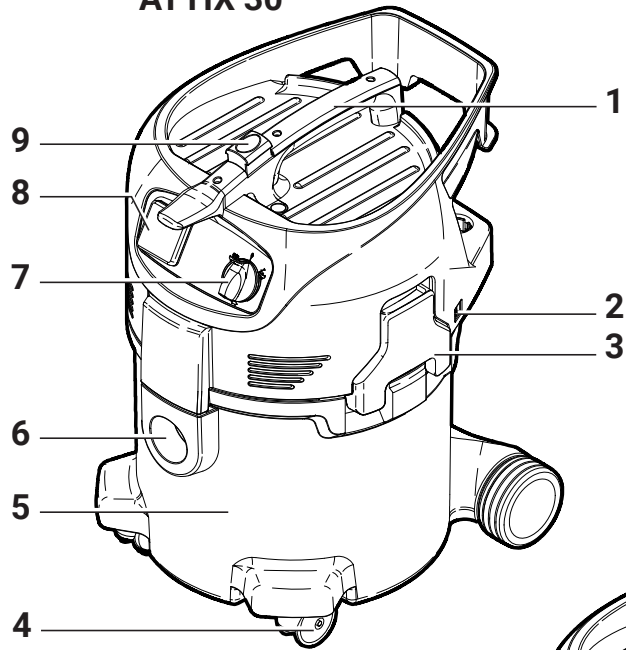

ATTIX 50

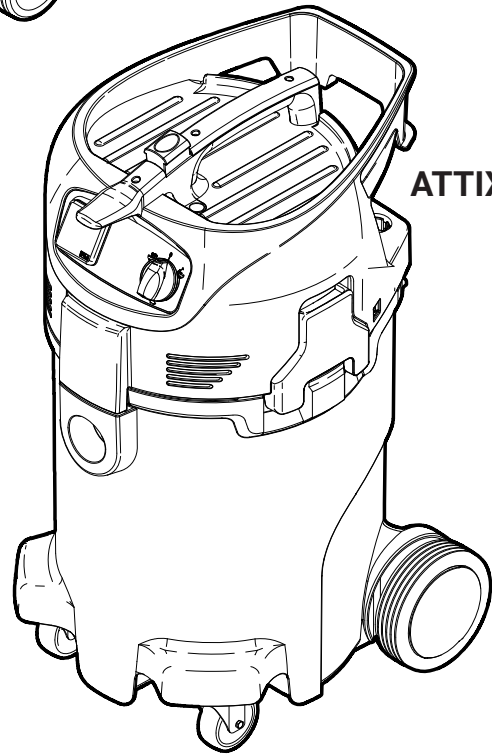

ATTIX 40

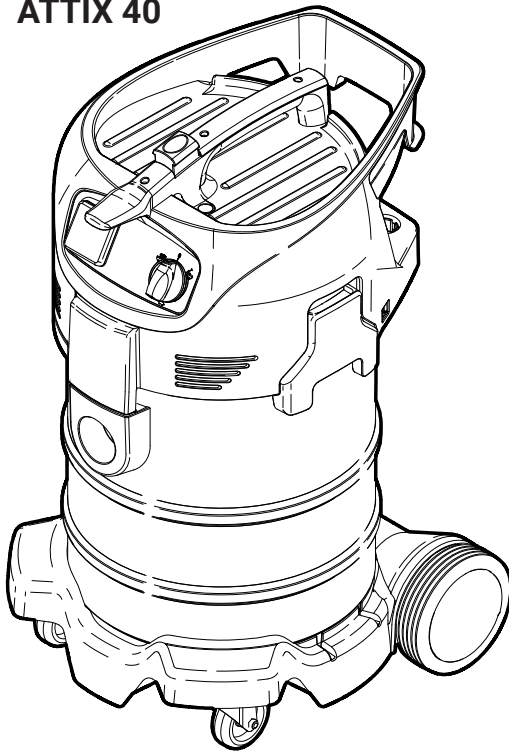

A

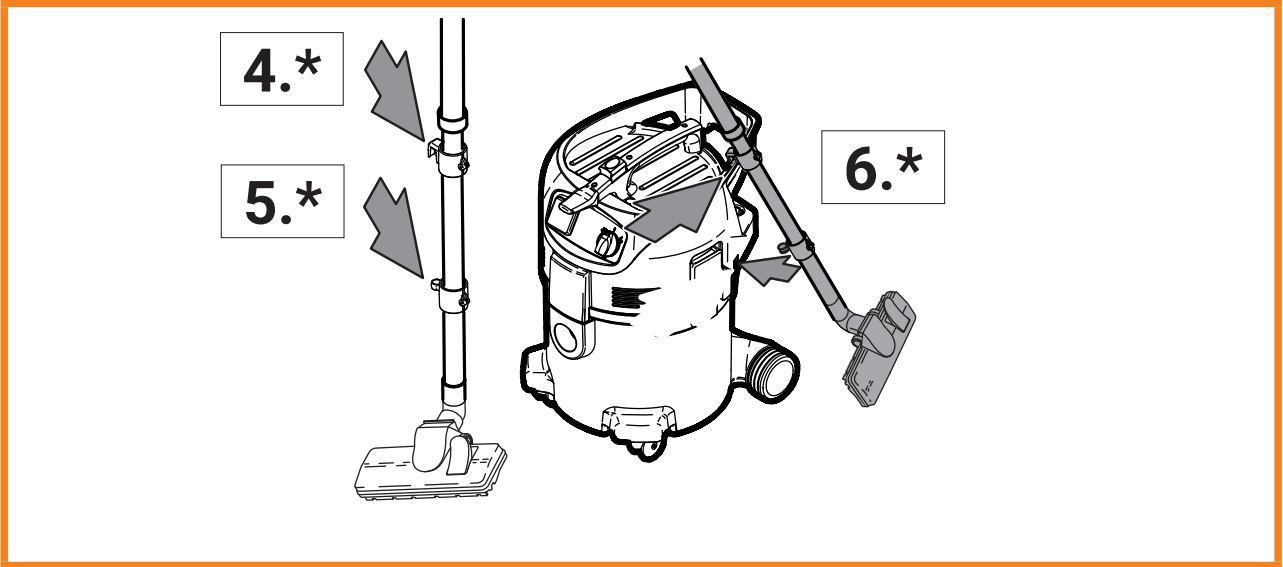
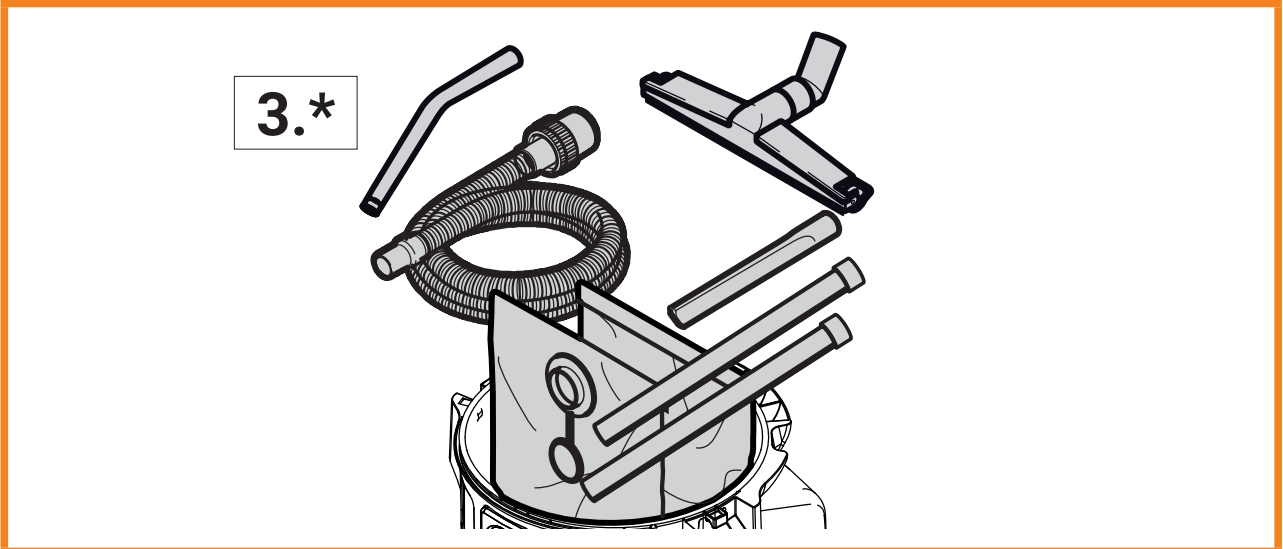
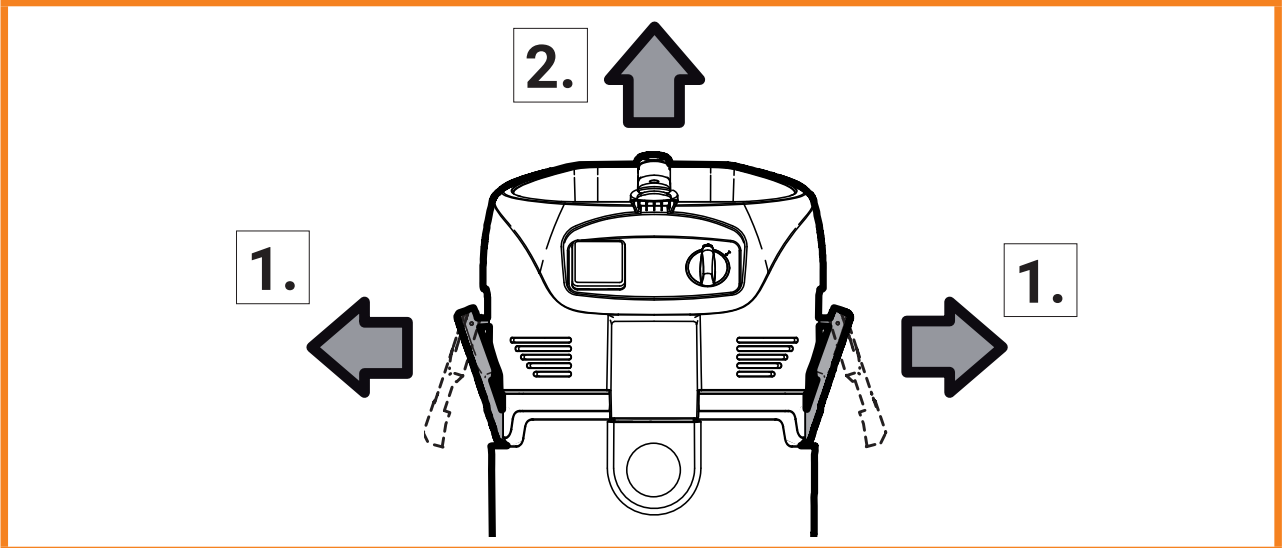
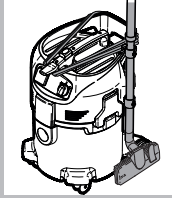

A

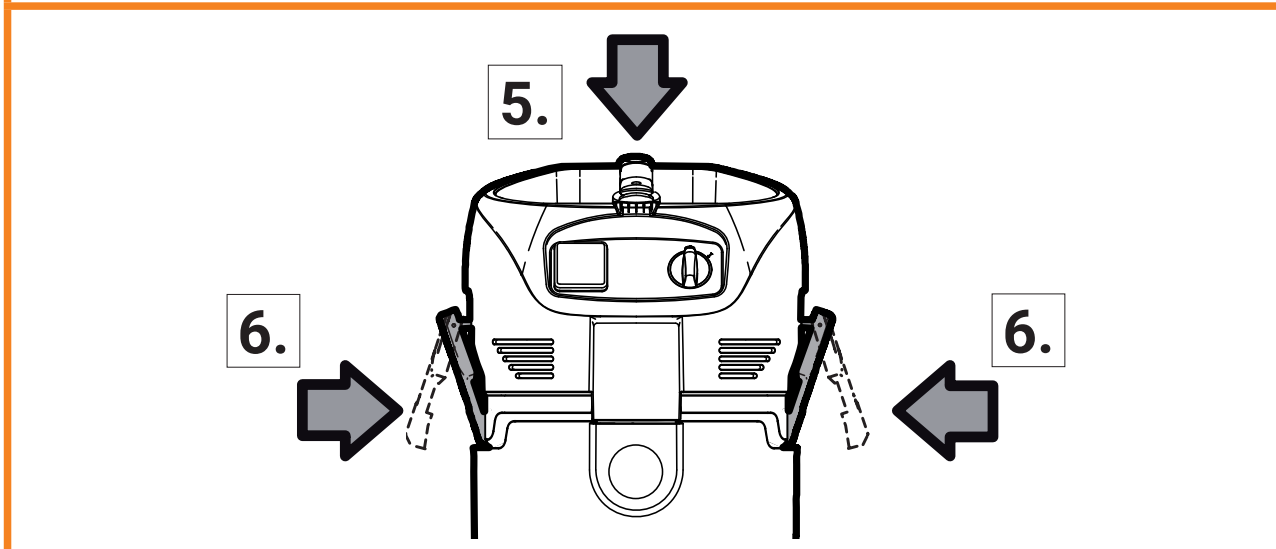
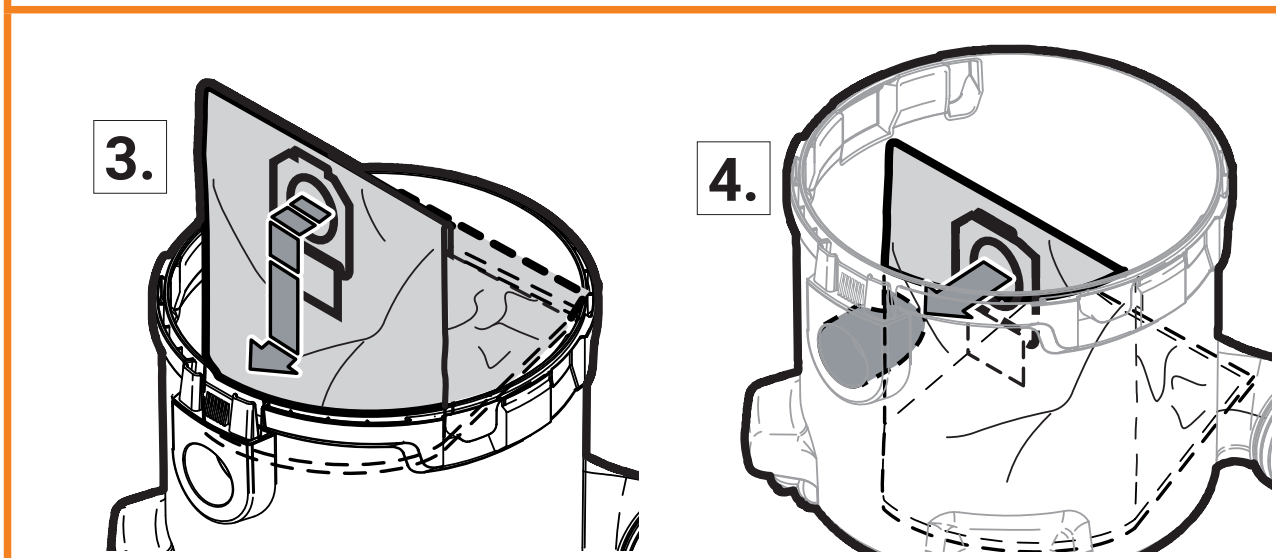
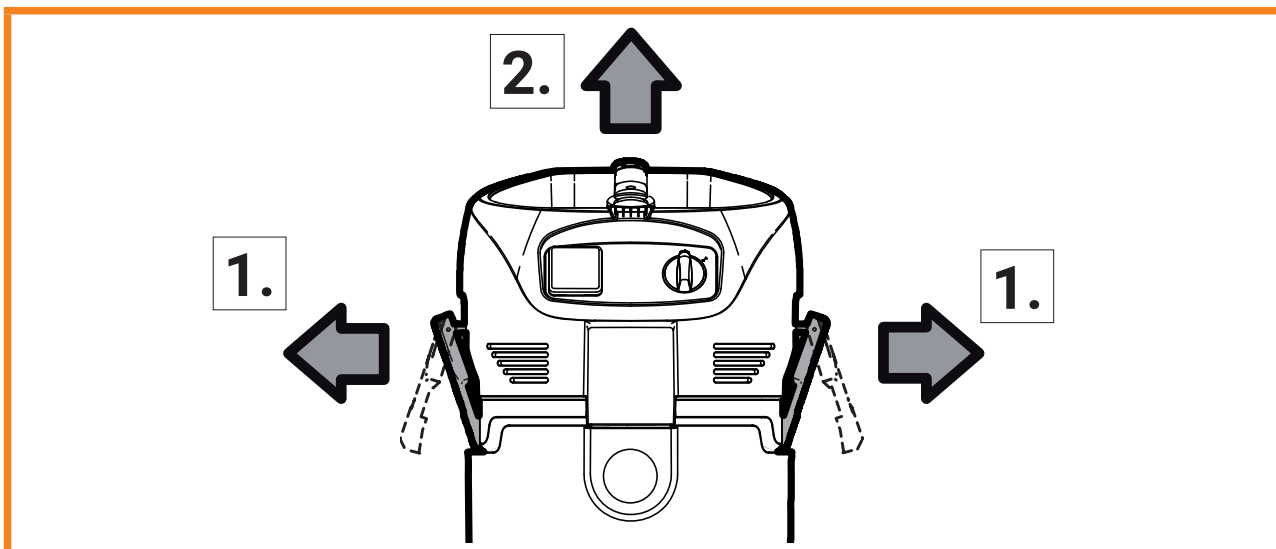
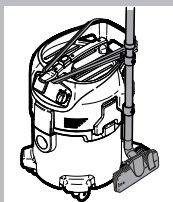

B



1.

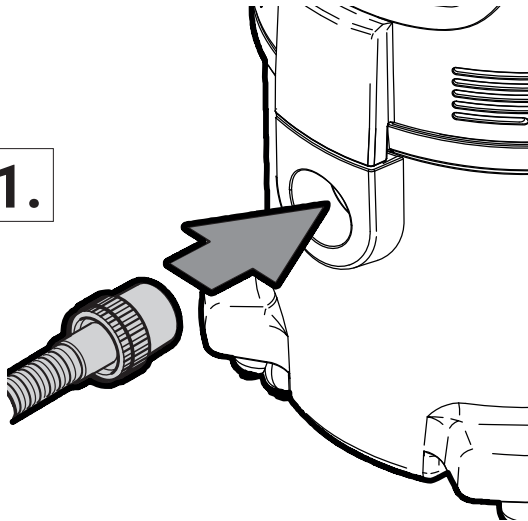

2.

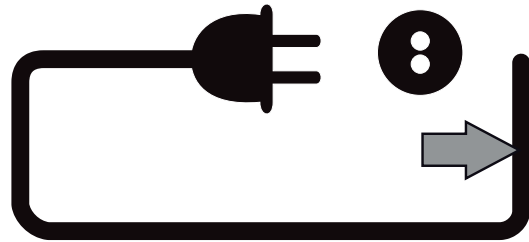

ATTIX 30- / 40- / 50-01
ATTIX 30- / 40- / 50-11

ATTIX 30- / 40- / 50-21

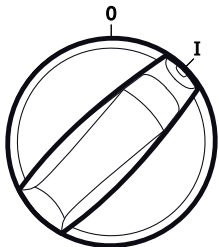

0 = ○
 I = ●

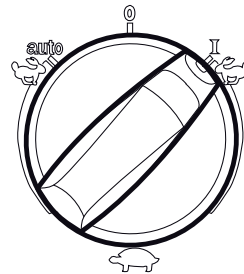

0 = ○
 I = ●
 auto =

ATTIX 30- / 40- / 50-21

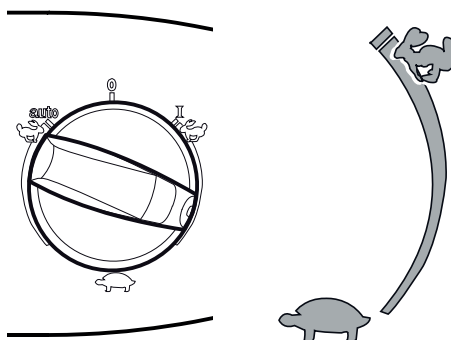

B



ATTIX 30- / 40- / 50-xx PC

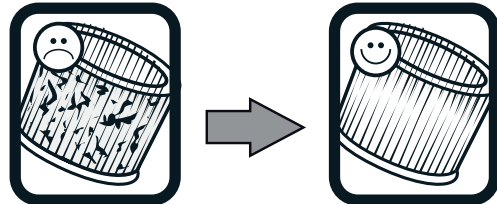

ATTIX 30- / 40- / 50-xx XC

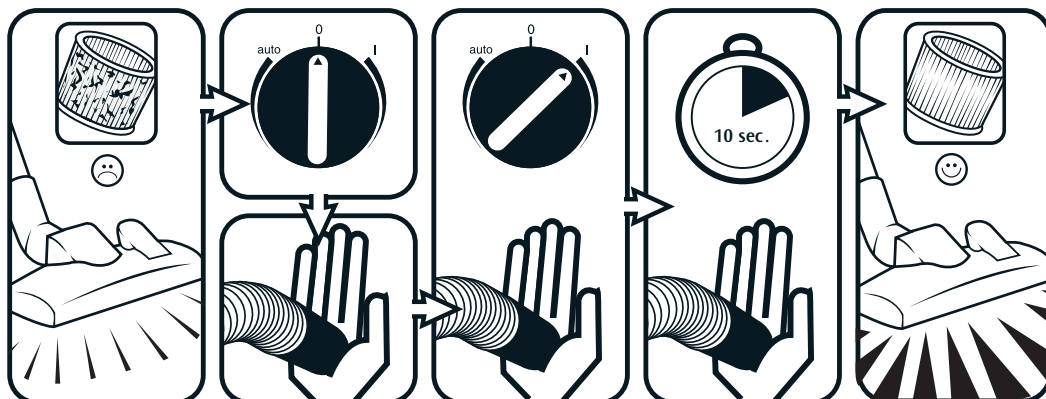
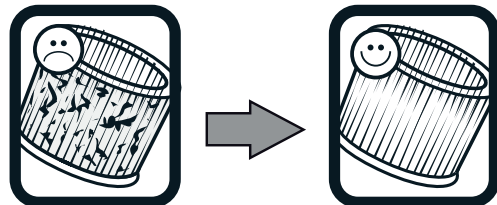

B*

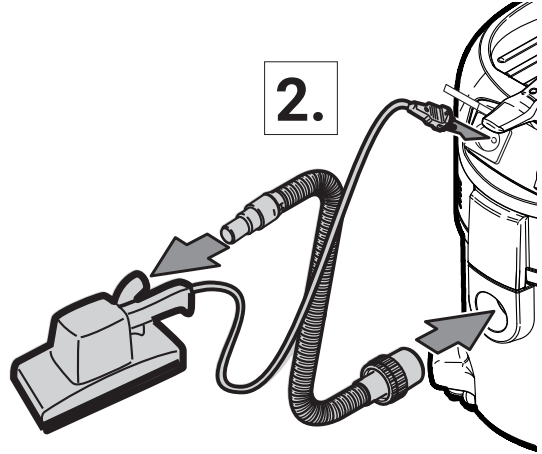
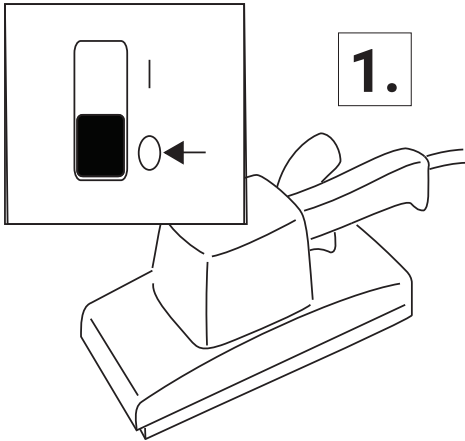
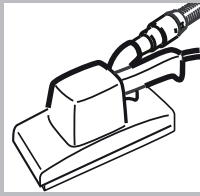

3.

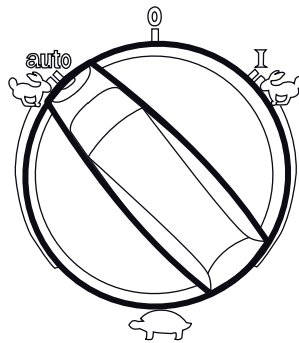

4.

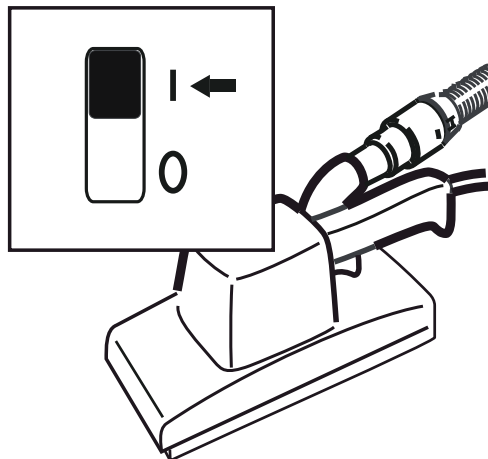

C

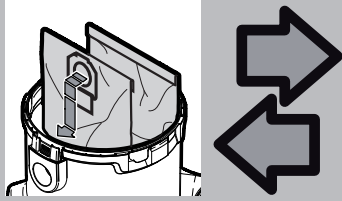

ATTIX 30 / 40 / 50

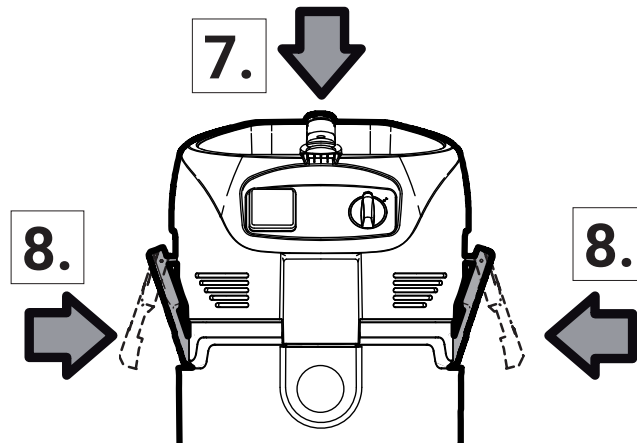
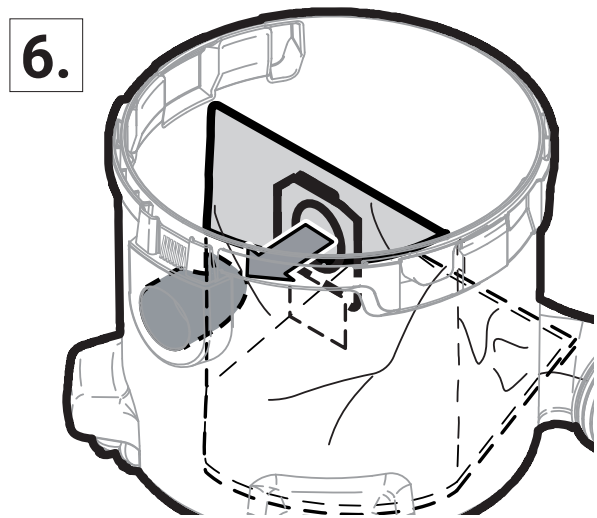
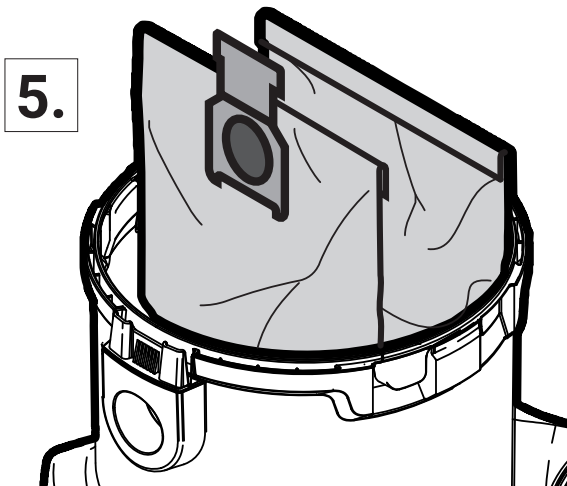
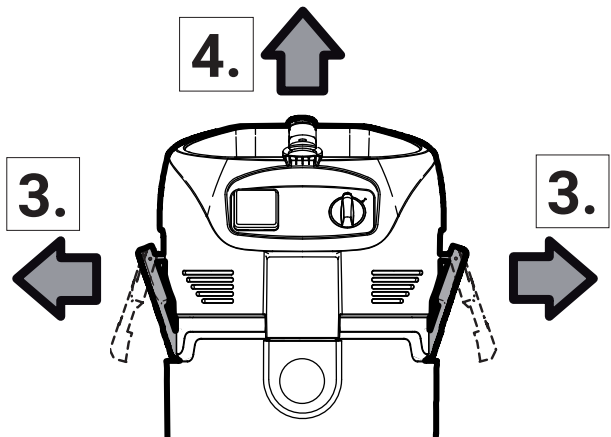
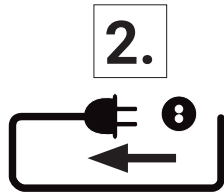
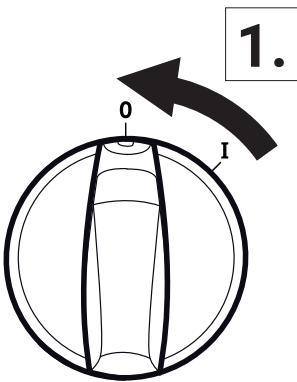

C



ATTIX 30 / 40 / 50

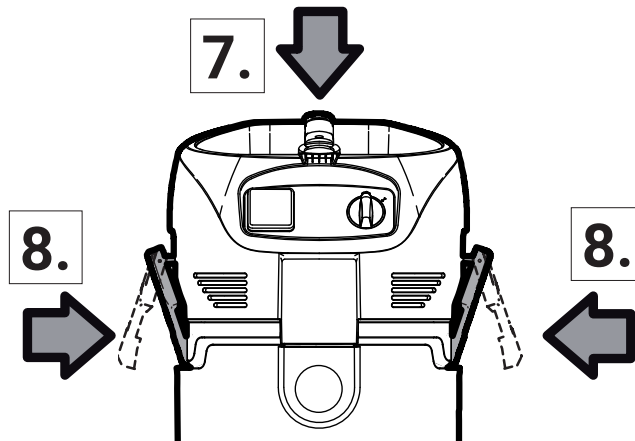
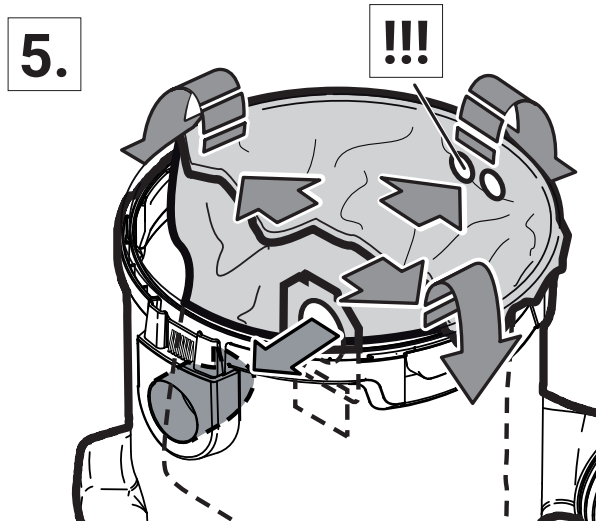
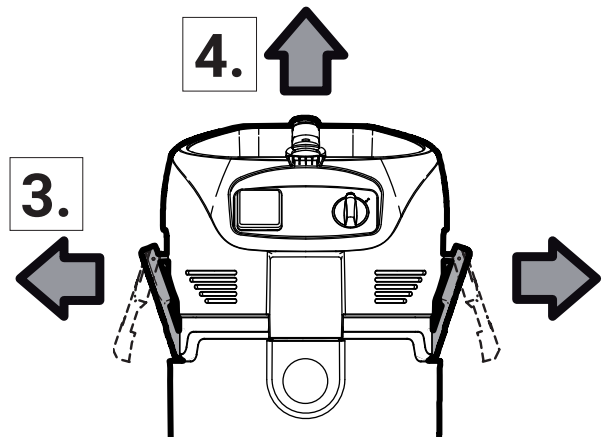
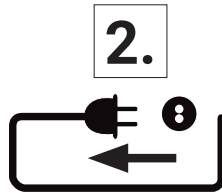
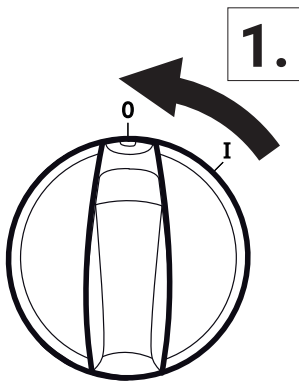

C



ATTIX 30 / 40 / 50 / STD / PC

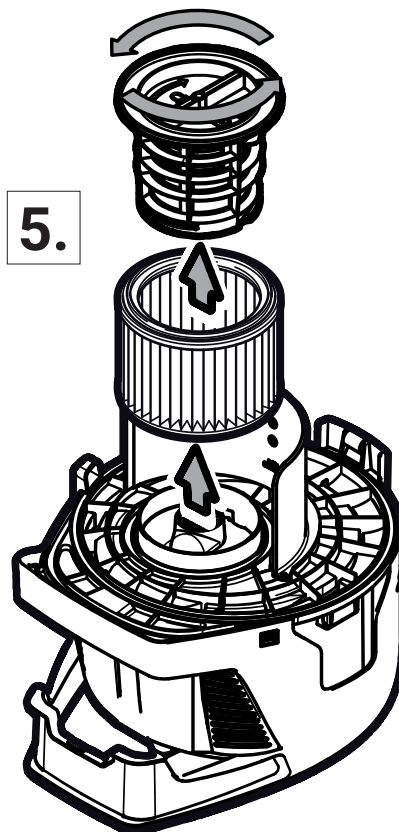
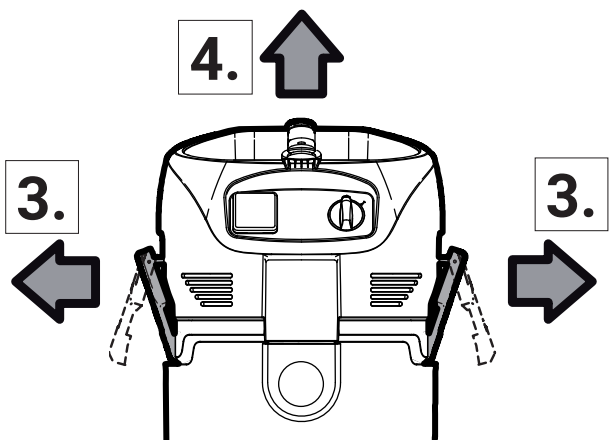
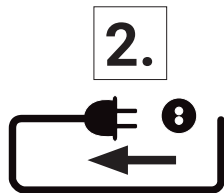
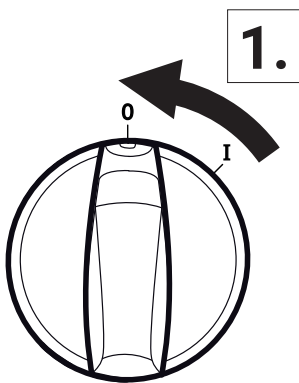

C



ATTIX 30 / 40 / 50 XC

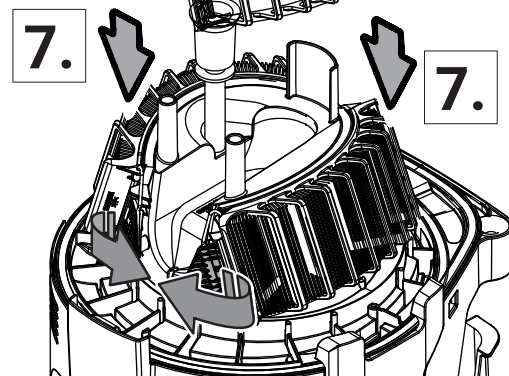
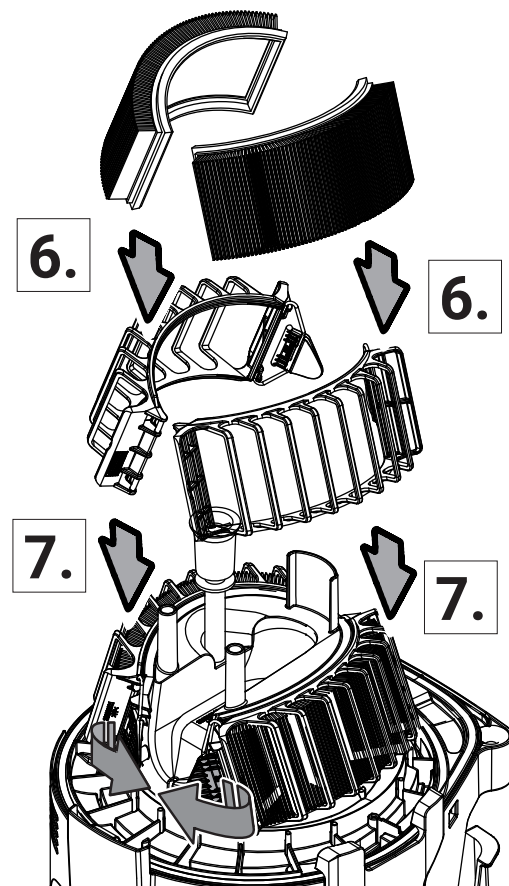
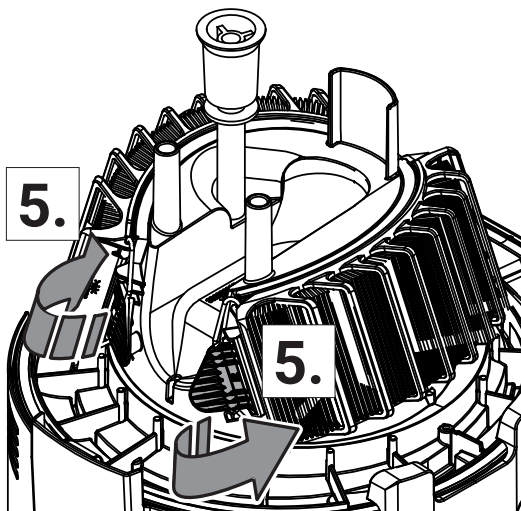
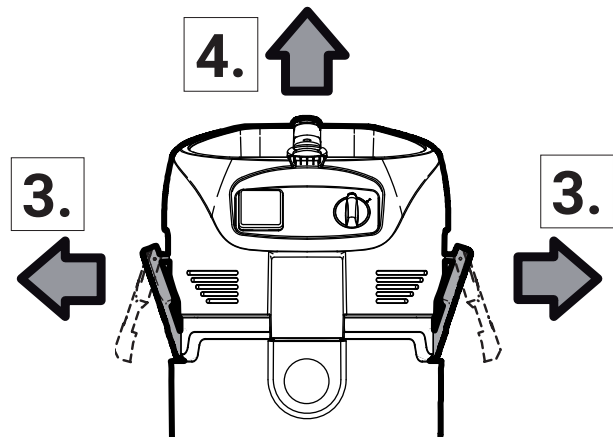
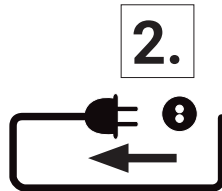
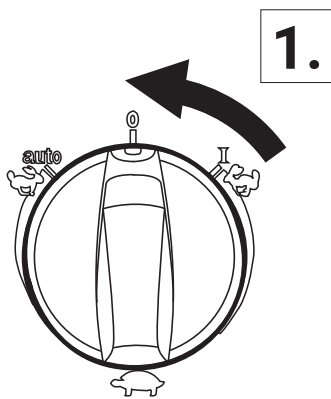

D

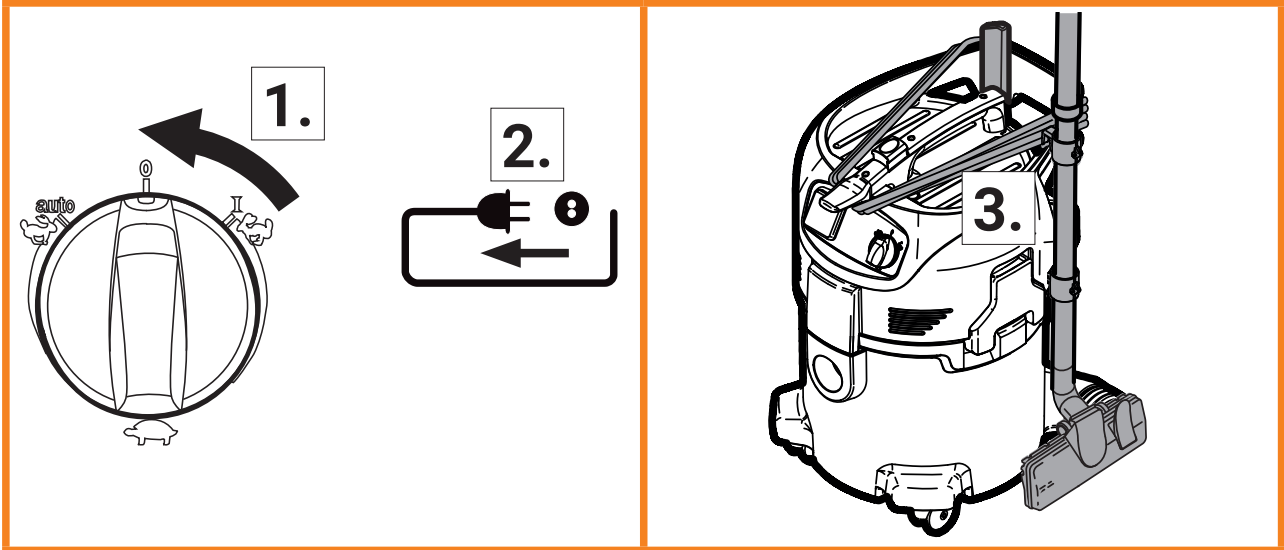
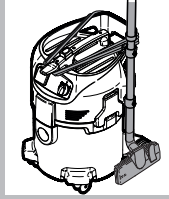

1 IMPORTANT SAFETY INSTRUCTIONS

1.1 Symbols used to mark instructions

DANGER

 Danger that leads directly to serious or irreversible injuries, or even death.

WARNING

 Danger that can lead to serious injuries or even death.

CAUTION

 Danger that can lead to minor injuries and damage.

 Before starting up your machine for the first time, this instruction manual must be read through carefully. Save the instructions for later use.

1.2 Instructions for use

Besides the operating instructions and the binding accident prevention regulations valid in the country of use, observe recognised regulations for safety and proper use.

1.3 Purpose and intended use

This machine is designed for industrial use, such as e.g. plants, construction sites and workshops. This machine is also intended for commercial use, for example in hotels, schools, hospitals, factories, shops, offices and rental businesses. Accidents due to misuse can only be prevented by those using the machine. The appliance is suitable for picking up dry, non-flammable dust and liquids

Any other use is considered as improper use. The manufacturer accepts no liability for any damage resulting from such use. The risk for such use is borne solely by the user. Proper use also includes proper operation, servicing and repairs as specified by the manufacturer.

READ AND FOLLOW ALL SAFETY INSTRUCTIONS.



For Dust Class L machines (with type designation -0L, 2L, LC) following applies:
The appliance is suitable for picking up dry, non-flammable dust, hazardous dusts with OEL¹⁾ value > 1mg/m³. Dust Class L (IEC 60335-2-69). The dusts which belong to this class have OEL¹⁾ values > 1mg/m³. For machines intended for the Dust Class L, the filter material is tested. The maximum degree of permeability is 1% and there is no special requirement for disposal. Observe national regulations before use. For dust extractors, ensure adequate air change rate L, when the exhaust air is returned to the room.

1.4 Important warnings

WARNING

- To reduce the risk of fire, electric shock, or injury, please read and follow all safety instructions and caution markings before use. This vacuum cleaner is designed to be safe when used for cleaning functions as specified. Should damage occur to electrical or mechanical parts, the cleaner and / or accessory should be repaired by a competent service station or the manufacturer before use in order to avoid further damage to the machine or physical injury to the user.

- Children shall be supervised to make sure that they do not play with the appliance.
- Cleaning and user maintenance shall not be made by children without supervision.
- This appliance is not intended for use by persons (including children) with reduced physical, sensory or mental capabilities, or lack of experience and knowledge.
- Outdoor use of the appliance shall be limited to occasional use.
- This machine shall only be stored indoors.
- Do not leave the machine when it is plugged in. Unplug from the socket when not in use and before maintenance.
- Do not use with damaged cord or plug. To unplug grasp the plug, not the cord. Do not handle plug or cleaner with wet hands. Turn off all controls before unplugging.
- Do not pull or carry by cord, use cord as a handle, close a door on cord, or pull cord around sharp edges or corners. Do not run cleaner over cord. Keep cord away from heated surfaces.
- Keep hair, loose clothing, fingers and all parts of the body away from openings and moving parts. Do not put any objects into openings or use with opening blocked. Keep openings free of dust, lint, hair, and anything else that could reduce the flow of air.
- Do not use in outside areas at low temperature.
- Do not use to pick up flammable or combustible liquids such as gasoline, or use in areas where they may be present.
- Do not pick up anything that is burning or smoking, such as cigarettes, matches or hot ashes.
- Use extra care when cleaning on stairs.
- Do not use unless filters are fitted.
- If the cleaner is not working properly or has been dropped, damaged, left outdoors, or dropped into water, return it to a service center or dealer.
- Operators shall be adequately instructed on the use of these machines.
- The machine may not be used as a water pump. The machine is intended for vacuuming air and water mixture.
- Connect the machine to a properly earthed mains supply. The socket outlet and the extension cable must have an operative protective conductor.
- Provide for good ventilation at the working place.
- Do not use the machine as a ladder or step ladder. The machine

can tip over and become damaged. Danger of injury.

- Only use the socket outlet on the machine for purposes specified in the Instructions.
- If foam or liquid escapes from the machine, switch off immediately.

1.5 Double-insulated appliances*)

CAUTION

- Use only as described in this manual and only with the manufacturer's recommended attachments.
- BEFORE YOU PLUG IN YOUR CLEANER, check the rating plate at the cleaner to see if the rated voltage agrees within 10% of the voltage available.
- This appliance is provided with double insulation. Use only identical replacement parts. See instructions for servicing double insulated appliances.
- Clean the water level limiting device regularly and examine it for signs of damage.

In a double-insulated appliance, two systems of insulation are provided instead of grounding. No grounding means is provided on a double-insulated appliance, nor should a mean for grounding be added to the appliance. Servicing a double-insulated appliance requires extreme care and knowledge of the system, and should be done only by qualified service personnel. Replacement parts for a double-insulated appliance must be identical to the parts they replace. A double insulated appliance is marked with the words "DOUBLE INSULATION" or "DOUBLE INSULATED." The symbol (square within a square) may also be used on the product.

The machine is equipped with a specially designed cord which if damaged, must be replaced by a cord of the same type. This is available at authorised service centres and dealers and must be installed by trained personnel.

Only applicable to UK.

Please read these essential instructions

These instructions have been prepared with safety and efficiency paramount.

The machine operator must be trained by a suitably qualified instructor and must understand these instructions for use, and be made aware of any relevant regulations and legislation in force at the time of use.

CAUTION

DOUBLE-INSULATED MACHINES - IMPORTANT:

This 240 volt 50 Hz. machine is fitted with a 13 amp. 3 pin moulded plug. The plug is fitted with a 13 amp. detachable fuse. The correct replacement for the fuse is identified by marking or colour coding. Only fuses that are ASTA approved to BS 1362 should be fitted. Never use the plug without the fuse cover fitted. Replacement fuse covers are available at any electrical retail outlet.

If the available socket outlet is not suitable for the plug supplied, the plug must be cut off and an appropriate plug fitted. The plug thus cut off MUST BE DESTROYED for safety reasons before being disposed of.

Machines built for other voltages and frequencies are not normally supplied with a fitted plug. If it is necessary to fit a plug, the wires in this power supply cord are coloured in accordance with the following code:

Blue-neutral brown-live

TO CONNECT THE NEW PLUG:

If using a three-pin plug, do not make any connection to the terminal in the plug which is marked with the letter 'E' or by the safety earth symbol or coloured green or green & yellow.

The blue wire must be connected to the terminal in the plug which is marked with the letter 'N' or is coloured black or blue.

The brown wire which must be connected to the terminal in the plug which is marked with the letter 'L' or is coloured red or brown.

If the plug to be fitted does not conform to the above notation then consult a qualified electrician.

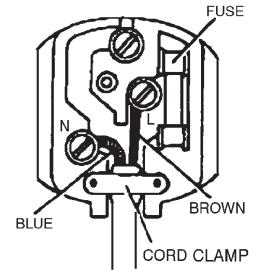

1.6 Electrical connection

WARNING

- The upper section of the machine contains live components. Contact with live components leads to serious or even fatal injuries. Never spray water on to the upper section of the machine.
- The vacuum cleaner must not be used if the electrical cable or plug show any sign of damage. Regularly inspect the cable and the plug for damage. If this becomes damaged, it should be repaired only by Nilfisk or an authorised Nilfisk Service Dealer, in order to avoid a hazard.
- Do not handle the electrical cable or plug with wet hands.
- Do not unplug by pulling on cable. To unplug, grasp the plug, not the cable. The plug must always be removed from the socket outlet before starting any service or repair work of the machine or the cable.
- In no circumstances should the power supply cord be wrapped around fingers or any part of the operators person.
- It is recommended that the machine should be connected via a residual current circuit breaker.
- Arrange the electrical parts (sockets, plugs and couplings) and lay down the extension lead so that the protection class is maintained.
- Connectors and couplings of power supply cords and extension leads must be watertight.

Extension lead

- As an extension lead, only use the version specified by the manufacturer or one of a higher quality.
- When using an extension lead, check the minimum cross-sections of the cable:

Cable length	Cross section	
	< 16 A	< 25 A
up to 20 m	1.5 mm ²	2.5 mm ²
20 to 50 m	2.5 mm ²	4.0 mm ²

1.7 Hazardous materials

WARNING

Vacuuuming up hazardous materials can lead to serious or even fatal injuries.

The following materials must not be picked up by the machine:

- hot materials (burning cigarettes, hot ash, etc.)
- flammable, explosive, aggressive liquids (e.g. petrol, solvents, acids, alkalis, etc.)
- flammable, explosive dust (e.g. magnesium or aluminium dust, etc.)

For standard machines (without type designation -0L, 2L, LC) following further applies: The following materials must not be picked up by the machine:

- Hazardous dust.

1.8 Maintenance

Remove the plug from the socket before performing maintenance. Before using the machine make sure that the frequency and voltage shown on the rating plate correspond with the mains voltage.

The machine is designed for continuous heavy work. Depending on the number of running hours – the dust filter should be renewed. Keep the machine clean with a dry cloth, and a small amount of spray polish.

During maintenance and cleaning, handle the machine in such a manner that there is no danger for maintenance staff or other persons.

In the maintenance area

- Use filtered compulsory ventilation
- Wear protective clothing
- Clean the maintenance area so that no harmful substances get into the surroundings.

For Dust Class L machines (with type designation -0L, 2L, LC) following applies:

During maintenance and cleaning, handle the machine in such a manner that there is no danger for maintenance staff or other persons.

In the maintenance area

- Use filtered compulsory ventilation
- Wear protective clothing
- Clean the maintenance area so that no harmful substances get into the surroundings.

During maintenance and repair work all contaminated parts that could not be cleaned satisfactorily must be:

- Packed in well sealed bags
- Disposed of in a manner that complies with valid regulations for such waste removal.

1.9 Regular servicing and inspection

Regular servicing and inspection of your machine must be carried out by suitably qualified personnel in accordance with relevant legislation and regulations. In particular, electrical tests for earth continuity, insulation resistance, and condition of the flexible cord should be checked frequently.

In the event of any defect, the machine **MUST** be withdrawn from service, completely checked and repaired by an authorized service technician.

At least once a year, a Nilfisk technician or an instructed person must perform a technical inspection including filters, air tightness and control mechanisms.

For details of after sales service contact your dealer or Nilfisk service representative responsible for your country. See reverse of this document.

2.0 Warranty

Our general conditions of business are applicable with regard to the guarantee.

Unauthorised modifications to the appliance, the use of incorrect brushes in addition to using the appliance in a way other than for the intended purpose exempt the manufacturer from any liability for the resulting damage.



Equipment marked with the crossed-out wheeled bin symbol indicates that used electrical and electronic equipment should not be discarded together with unseparated household waste. To avoid negative effects on human health and the environment the equipment must be collected separately at the designated collection points.

Users of electrical and electronic household equipment must use the municipal collection schemes. Please note that commercially used electrical and electronic equipment, shall not be disposed of via municipal collection schemes. We will be pleased to inform you about suitable disposal options.

Quick reference guide







Operating elements

1. Handle with receptacle for electrical lead
2. Fixing point for suction pipe holder
3. Retaining clamp
4. Castor
5. Dirt tank
6. Inlet fitting
7. Appliance switch
8. Appliance socket *)
9. Operating knob for filter cleaning *)

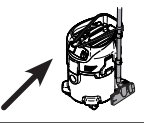
Pages 2 – 12 feature a pictorial quick reference guide, which is designed to help you when starting up, operating and storing the appliance.

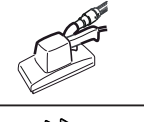
Meaning of the symbols

The instructions for actions are subdivided into 7 sections, which are represented by symbols.

	A Before starting
	B Control / Operation
	B Connecting electrical appliances
	C Replacement of filter bag
	C Replacement of disposal bag
	C Replacement of filter element
	D After finishing work

An asterisk (*) indicates a model variant or special accessories.

Check whether your appliance is equipped with the control elements or special accessories depicted. If not, please proceed to the next action.

Techniques

If used correctly, additional accessories, suction nozzles and suction hoses can enhance the cleaning action and reduce the cleaning effort. Effective cleaning is achieved if you follow just a few guidelines in combination with your own practical experience in special fields.

Here are some basic tips.

Picking up dry substances

Before picking up dry substances, always ensure that a filter bag is inserted in the tank (see section "Accessories" for order number). Disposal of the picked up material is then simple and hygienic.

After picking up liquids, the filter element is wet. A damp filter element clogs more quickly when dry substances are picked up. For this reason the filter element should be washed and dried or replaced by a dry element before dry substances are picked up.

Picking up liquids

Before liquids are picked up, always remove the filter bag/disposal bag.

The use of a separate filter element or filter screen is recommended. Does not apply to XC machines.

Transport

Before transporting the dirt tank, close all the locks. Do not tilt the appliance if there is liquid in the dirt tank. Do not use a crane hook to lift the appliance. Handle the appliance with care during transport.

Specifications

ATTIX 30 / 40 / 50											50-21 PC EC	
	EU	CH / DK	GB	GB	US	FR	AU/NZ	ZA			EU	
Voltage	V	220-240	110-120	120	120	220-240	220-240	220-240			220-240	220-240
Mains frequency	Hz	50 / 60		60	60	50				50	50/60	
Fuse	A	16	10	13	15	16	10	13			16	16
Power consumption _{IEC}	W	1200		1000	1000	1200				1200	1100	1100
Connected load for appliance socket	W	2400	1100	1750	800	2400	1100	1750			2400	2400
Total connected load	W	3600	2300	2950	1800	3600	2300	2950			3600	3500
Maximum flow rate	m ³ /h (litres/ min)	222 (3700)		192 (3200)	192 (3200)	222 (3700)				222 (3700)	261 (4350)	
Maximum underpressure (water lift)	hPa (in)	250 (7,38)		230 (6,79)	230 (6,79)	250 (7,38)				250 (7,38)	230 (6,79)	
Sound pressure level L _{PA} (IEC 60335-2-69)	dB(A)			67 ± 2	67 ± 2							
Vibration ISO 5349 a _h	m/s ²			≤ 2,5	≤ 2,5							
Working sound level	dB(A)			59 ± 2	59 ± 2							
Protection class				I	I							
Protection grade (moist, dust)				IP X4	IP X4							
Weight	Kg (lb)			10-14 (22-30)	10-14 (22-30)						11 (24)	

Specifications and details are subject to change without prior notice.



EU / UE / EL / EC / EE / ES / EÚ / AB / EG

Declaration of Conformity

Prohlášení o shodě
Konformitätserklärung
Overensstemmelseserklæring
Declaración de conformidad
Vastavusdeklaratsioon
Déclaration de conformité
Vaatumustenmukaisuusvakuutus

Декларация за съответствие
Δήλωση συμμόρφωσης
Megfelelősségi nyilatkozat
Izjava o skladnosti
Dichiarazione di conformità
Atitikties deklaracija
Atbilstības deklarācija
Samsvarserklæring
Conformiteitsverklaring

Declaração de conformidade
Deklaracja zgodności
Declaratie de conformitate
Декларация о соответствии
Försäkran om överensstämmelse
Vyhlášení o zhode
Izjava o skladnosti
Uygunluk beyanı

Manufacturer / Výrobce / Hersteller / Fabrikant /
Fabricante / Κατασκευαστής / Gyártó / Proizvođač /
Fabbricante / Gamintojas / Ražotājs / Producers /
Fabrikant / Fabricante / Producent / Producător /
производитель / Tillverkaren / Výrobca / Proizvajalec /
Üretici firma:

**Nilfisk A/S, Kornmarksvej 1
DK-2605 Broendby, DENMARK**

Product / Produkt / Producto, Toode, Produit, Tuote/
Продукт / Προϊόν / Termék / Proizvod / Prodotto /
Produktas / Produkts / Artikel / Produtos / Prods /
Izdelek / Ürün

ATTIX 30/40/50 PC/XC/EC

Description / Popis / Beschreibung / Beskrivelse /
Descripción / Kirjeldus / La description / Kuvaus /
Описание / Περιγραφή / Leirás / Opis / Descrizione /
Aprašymas / Apraksts / Beschrijving / Descrição /
Descriere / Beskrivning / Popis / Açıklama

**VAC - Commercial - Wet/Dry
220-240V 50-60Hz, IPX4**

EN

We, Nilfisk hereby declare under our sole responsibility, that the above-mentioned product(s) is/are in conformity with the following directives and standards.

CS

My, Nilfisk prohlašujeme na svou výlučnou odpovědnost, že výše uvedený výrobek je ve shodě s následujícími směrnici a normami.

DE

Wir, Nilfisk erklären in alleiniger Verantwortung, dass das oben genannte Produkt den folgenden Richtlinien und Normen entspricht.

DA

Vi, Nilfisk erklærer hermed under eget ansvar at ovennævnte produkt(er) er i overensstemmelse med følgende direktiver og standarder.

ES

Nosotros, Nilfisk declaramos bajo nuestra única responsabilidad que el producto antes mencionado está en conformidad con las siguientes directivas y normas

ET

Meie, Nilfisk Käesolevaga kinnitame ja kanname ainuisikulist vastutust, et eespool nimetatud toode on kooskõlas järgmiste direktiivide ja

LT

Mes, „Nilfisk“, prisiimdami visišką atsakomybę pareiškiame, kad pirmiau minėtas produktas (-ai) atitinka šias direktyvas ir standartus

LV

Mēs, Nilfisk, ar pilnu atbildību apliecinām, ka iepriekšminētais produkts atbilst šādām direktīvām un standartiem

NO

Vi, Nilfisk erklærer herved under eget ansvar, at det ovennevnte produktet er i samsvar med følgende direktiver og standarder

NL

We verklaren Nilfisk hierbij op eigen verantwoordelijkheid, dat het bovengenoemde product voldoet aan de volgende richtlijnen en normen

PT

Nós, a Nilfisk declaramos, sob nossa exclusiva responsabilidade, que o produto acima mencionado está em conformidade com as diretrizes e normas a seguir

PL

My, Nilfisk Niniejszym oświadczamy z pełną odpowiedzialnością, że wyżej wymieniony produkt jest zgodny z następującymi dyrektywami i normami..

<p>FR Nilfisk déclare sous notre seule responsabilité que le produit mentionné ci-dessus est conforme aux directives et normes suivantes.</p>	<p>RO Noi, Nilfisk Prin prezenta declarăm pe propria răspundere, că produsul mai sus menționat este în conformitate cu următoarele standarde și directive</p>
<p>FI Me, Nilfisk täten vakuutamme omalla vastuulla, että edellä mainittu tuote on yhdenmukainen seuraavien direktiivien ja standardien mukaisesti</p>	<p>RU Мы, Nilfisk настоящим заявляем под нашу полную ответственность, что вышеперечисленные продукция соответствует следующими директивам и стандартам.</p>
<p>BG Ние, Nilfisk С настоящото декларираме на своя лична отговорност, че посочените по-горе продуктът е в съответствие със следните директиви и стандарти.</p>	<p>SV Vi Nilfisk förklarar härmed under eget ansvar att ovan nämnda produkt överensstämmer med följande direktiv och normer.</p>
<p>EL Εμείς, Nilfisk δηλώνουμε με αποκλειστική μας ευθύνη, ότι το προαναφερόμενο προϊόν συμμορφώνεται με τις ακόλουθες οδηγίες και πρότυπα.</p>	<p>SK My, Nilfisk prehlasujeme na svoju výlučnú zodpovednosť, že vyššie uvedený výrobok je v zhode s nasledujúcimi smernicami a normami.</p>
<p>HU Mi, Nilfisk Kijelentjük, egyedüli felelősséggel, hogy a fent említett termék megfelel az alábbi irányelveknek és szabványoknak</p>	<p>SL Mi, Nilfisk izjavljamo s polno odgovornostjo, da je zgoraj omenjeni izdelek v skladu z naslednjimi smernicami in standardi.</p>
<p>HR Mi, Nilfisk Izjavljujemo pod punom odgovornošću, da gore navedeni proizvod u skladu sa sljedećim direktivama i standardima.</p>	<p>TR Nilfisk, burada yer alan tüm sorumluluklarımıza göre, yukarıda belirtilen ürünün aşağıdaki direktifler ve standartlara uygun olduğunu beyan ederiz.</p>
<p>IT Noi, Nilfisk dichiara sotto la propria responsabilità, che il prodotto di cui sopra è conforme alle seguenti direttive e norme.</p>	

2006/42/EC	EN 60335-1:2012+A11:2014+A13:2017 +A1:2019+A14:2019+A2:2019 EN 60335-2-69:2012
2014/30/EU	EN 55014-1:2017+A11:2020 EN 55014-2:2015 EN 61000-3-2:2014 EN 61000-3-3:2013
2011/65/EU	EN 63000:2018

Authorized signatory: Pierre Mikaelsson, Executive Vice President, Global Products & Services, Nilfisk NLT

Apr 6, 2022





UK Declaration of Conformity

We,
Nilfisk Ltd
Nilfisk House, Bowerbank Way Gilwilly Industrial Estate
Penrith Cumbria
CA11 9BQ UK

Hereby declare under our sole responsibility that the

Products: VAC - Commercial - Wet/Dry
Description: 220-240V 50-60Hz, IPX4
Type: ATTIX 30/40/50 PC/XC/EC

Are in compliance with the following standards:

EN 60335-1:2012+A11:2014+A13:2017
EN 60335-2-69:2012
EN 55014-1:2017+A11:2020
EN 55014-2:2015
EN 61000-3-2:2014
EN 61000-3-3:2013
EN 63000:2018

Following the provisions of:

Supply of Machinery (Safety) Regulations 2008/1597
Electromagnetic Compatibility Regulations 2016/1091
The Restriction of the Use of Certain Hazardous Substances in Electrical and Electronic Equipment
Regulations 2012/3032

Penrith, 20-1-2021

A handwritten signature in black ink, appearing to read "Stewart Dennett".

Stewart Dennett
GM/MD



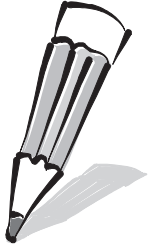

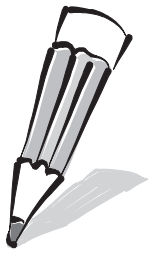

HEAD QUARTER

DENMARK

Nilfisk A/S
Tel.: +45 43 23 81 00
www.nilfisk.com

SALES COMPANIES

ARGENTINA

Nilfisk Argentina
Tel.: +54 11 4737 1877
www.nilfisk.com

AUSTRALIA

Nilfisk Pty Ltd
Tel.: +61 1300 556 710
www.nilfisk.com

AUSTRIA

Nilfisk GmbH
Tel.: +43 (0)662/45 64 00-90
www.nilfisk.com

BELGIUM

Nilfisk nv/sa
Tel.: +32 (0) 2 467 60 50
www.nilfisk.com

BRAZIL

Nilfisk do Brasil
Tel.: +55 11 3959-0300
www.nilfisk.com

CANADA

Nilfisk Canada Company
Tel.: +1 800-668-8400
www.nilfisk.com

CHILE

Nilfisk S.A. (Comercial KCS Ltda)
Tel.: +56 2 2684 5000
www.nilfisk.com

CHINA

Nilfisk
Tel.: +86 400 080 3200
www.nilfisk.com

CZECH REPUBLIC

Nilfisk s.r.o.
Tel.: +420 244 090 912
www.nilfisk.com

DENMARK

Nilfisk Danmark A/S
Tel.: +45 72 18 21 00
www.nilfisk.com

FINLAND

Nilfisk Oy Ab
Tel.: +358 207 890 602
www.nilfisk.com

FRANCE

Nilfisk SAS
Tel.: +33 169 59 87 00
www.nilfisk.com

GERMANY

Nilfisk GmbH
Tel.: +49 (0)7306-72-444
www.nilfisk.com

GREECE

Nilfisk A.E.
Tel.: +30 210 911 9600
www.nilfisk.com

NETHERLANDS

Nilfisk B.V.
Tel.: +31 036-5460700
www.nilfisk.com

HUNGARY

Nilfisk Kft.
Tel.: +36 24 507 452
www.nilfisk.com

INDIA

Nilfisk India Limited
Tel.: +91 80 4127 6510
www.nilfisk.com

IRELAND

Nilfisk
Tel.: +35 01 294 3838
www.nilfisk.com

ITALY

Nilfisk SpA
Tel.: +39 0523 1612000
www.nilfisk.com

JAPAN

Nilfisk Inc.
Tel.: +81 045-620-3658
www.nilfisk.com

MALAYSIA

Nilfisk Sdn Bhd
Tel.: +603 6275 3120
www.nilfisk.com

MEXICO

Nilfisk de Mexico, S. de R.L. de C.V.
Tel.: +52 442 427 7774
www.nilfisk.com

NEW ZEALAND

Nilfisk Limited
Tel.: +64 (09) 525 1130
www.nilfisk.com

NORWAY

Nilfisk AS
Tel.: +47 22 75 17 80
www.nilfisk.com

PERU

Nilfisk S.A.C.
Tel.: + 51 (1) 710 8283
www.nilfisk.com

POLAND

Nilfisk Sp. Z.O.O.
Tel.: +48 22 104 22 00
www.nilfisk.com

PORTUGAL

Nilfisk Lda.
Tel.: +351 219 112 670
www.nilfisk.com

SINGAPORE

Nilfisk Pte Ltd
Tel.: +65 62681006
www.nilfisk.com

SLOVAKIA

Nilfisk s.r.o.
Tel.: +421 948 339 353
www.nilfisk.com

SOUTH AFRICA

Nilfisk Middle East & Africa
Tel.: +971 4264 4172
www.nilfisk.com

SOUTH KOREA

Nilfisk Korea
Tel.: +82 02-3474-4141
www.nilfisk.com

SPAIN

Nilfisk S.A.U
Tel.: +34 900 506 776
www.nilfisk.com

SWEDEN

Nilfisk AB
Tel.: +46 031-706 73 00
www.nilfisk.com

SWITZERLAND

Nilfisk AG
Tel.: +41 (0)71 923 84 44
www.nilfisk.com

THAILAND

Nilfisk Co. Ltd.
Tel.: +66 0-2275-5630
www.nilfisk.com

TURKEY

Nilfisk A.S.
Tel.: +90 216 275 76 00
www.nilfisk.com

UNITED ARAB EMIRATES

Nilfisk Middle East Branch
Tel.: +971 4264 4172
www.nilfisk.com

UNITED KINGDOM

Nilfisk Ltd.
Tel.: +44 01768 868995
www.nilfisk.com

UNITED STATES

Nilfisk, Inc.
Tel.: +1 800-989-2235
www.nilfisk.com

VIETNAM

Nilfisk Vietnam
Tel.: +84 0866 461 566
www.nilfisk.com